



18  Island  
Bay

**SPORTSMAN**

*Owner's Manual and  
Quick-reference Guide  
2017*

# Table of Contents

<i>Topic</i>	<i>Page</i>
Introduction	3
Important Information	4
Specifications	5
Overall Dimensions & Terminology	6
Features & Performance	7
Certifications & Registrations	9
Boating Safety	10
Electrical & Plumbing Systems	16
Fuel System	21
Boating Navigation Rules	26
Warranty & Services	27
Contact Information	30





## Introduction

### WELCOME TO THE SPORTSMAN TEAM!

Here at Sportsman Boats, we take great pride in producing the finest, most well designed saltwater fishing and pleasure boats on the market today. Our designs incorporate the most modern technology while applying good old “Common Sense” technology as well. From our advanced composite construction, ergonomic console designs, patented “Total Access” hatch, and superior ride and handling characteristics, we think you will agree that Sportsman is setting a new standard.

We do not take lightly the confidence you have placed in us with your decision to purchase your Sportsman boat. We will always strive to provide for you and your family the superior customer service you deserve. We hope that you enjoy your time out on the water as much as we enjoy building your Sportsman boat!

Safe Boating and Tight Lines,  
*Tommy Hancock and Dale Martin*

**SPORTSMAN**

---



# Important Information

<b>BOAT INFORMATION / SPECIFICATIONS</b>	
MODEL:	HULL SERIAL #:
PURCHASE DATE:	DELIVERED:
IGNITION KEY #:	REGISTRATION #:
DRAFT:	WEIGHT:
VERTICAL CLEARANCE:	
<b>ENGINE / PROPELLER INFORMATION</b>	
ENGINE MAKE:	MODEL:
ENGINE SERIAL #:	
PROPELLER MAKE:	# OF BLADES:
DIAMETER / PITCH:	MODEL:
PART #:	
<b>OPTIONAL EQUIPMENT / OPTION PACKAGES</b>	
<b>TRAILER INFORMATION</b>	
MAKE:	MODEL:
SERIAL #:	GVRM:
ADDITIONAL INFORMATION:	
DEALER	SPORTSMAN
NAME:	PHONE:
PHONE:	REPRESENTATIVE:
SALES PERSON:	ADDRESS:
SERVICE MANGER:	
ADDRESS:	

We recommend filling out the information in this table and keeping one copy of this page in your personal records and one copy with your owner's manual. This information will be important should you need to contact your dealer or Sportsman Boats Manufacturing for technical assistance and/or service.



## Specifications

Length Overall	18'1"
Beam	7'1"
Draft	11.5"
Deadrise at Transom	14°
Approximate Usable Fuel Capacity	28 gal.
Approximate Dry Weight	1000 lbs.
People Capacity	5 persons
Maximum Engine Horse Power	90 HP (4 Stroke)

**SPORTSMAN**

# Overall Dimensions & Terminology

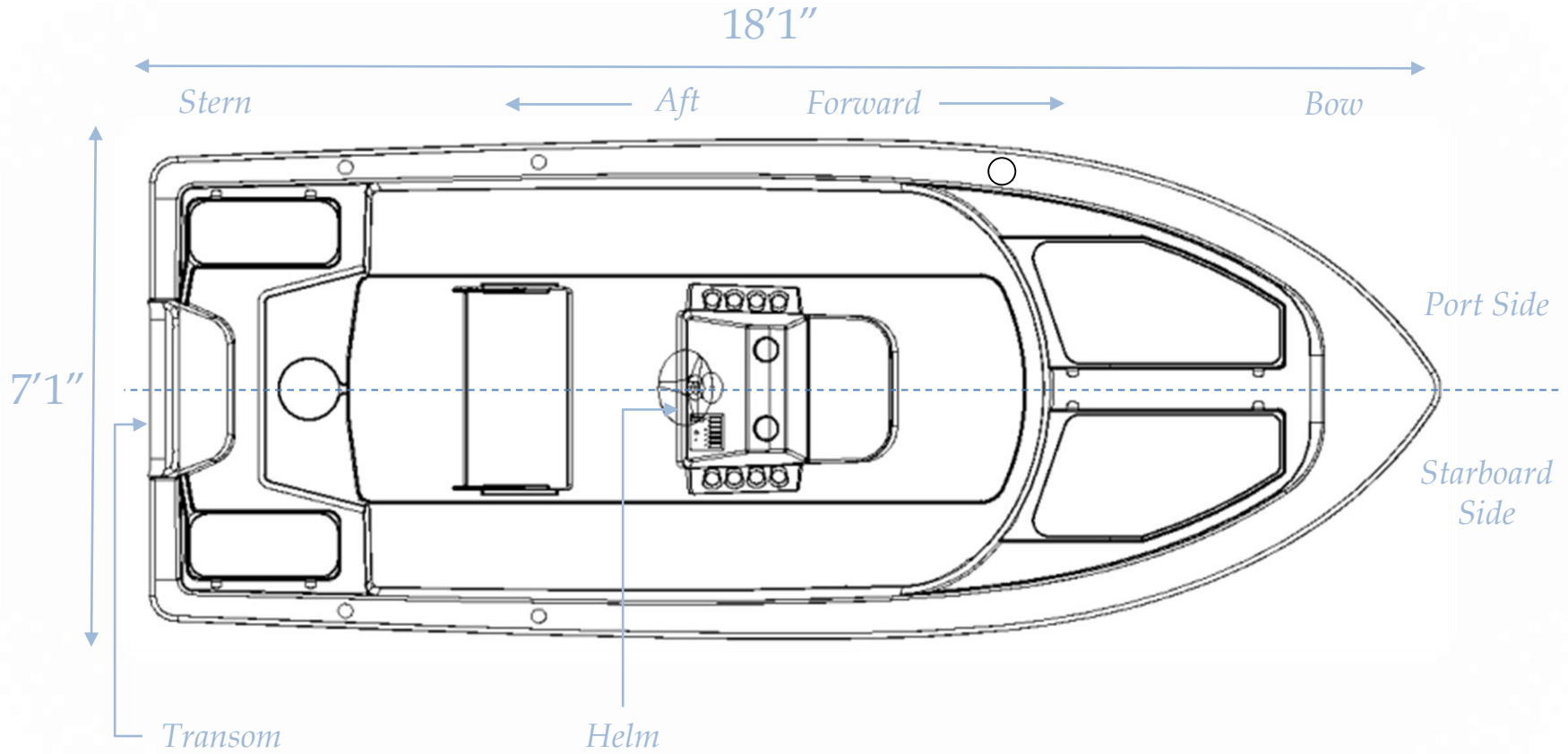

**SPORTSMAN**

# Features & Performance

## Standard

- |   |   |  |
|---|---|--|
| - 10 Year Hull Warranty                         | - Under Console Seat Storage                  | - NMMA Certified by ABYC Standards           |
| - 28 Approx. Usable Gallon Fuel Tank            | - Net   | - 2 Rear Storage Boxes with Push Drain Plugs |
| - 12 Volt Power Plug                            | - Console Storage                             | - Rear Livewell                              |
| - Go7 Simrad Display with Thru Hull Transducer  | - Cockpit Drain (Self-bailing Cockpit)        | - Rub Rail Nav. Lights                       |
| - 4 Flush-mounted Gunwale Rod Holders           | - Console Windscreen                          | - 2 Stainless Steel Cup Holders              |
| - 6 Flush-mounted Console Rod Holders           | - Deluxe Leaning Post with Removable Backrest | - Stainless Steel Drain Cover                |
| - Advanced Fiberglass Stringer System (no wood) | - Grip Tex Yacht Style Non-skid               | - Stainless Steel Drain Plug                 |
| - Aluminum Propeller                            | - Horn  | - 1 Stainless Steel Handrail                 |
| - Automatic Bilge Pump                          | - Hull Color                                  | - Stainless Steel Steering Wheel             |
| - Bow Storage                                   | - Large Bow Casting Deck                      | - Swim Platform with Ladder                  |
| - Console Grab Rail                             | - Large Rear Casting Deck                     | - Trolling Motor Plug/Harness                |
|   | - Mechanical Steering                         | - Yamaha Gauges                              |
|   | - Pull Up Cleats                              |  |

## Available Options

- |                |                 |
|----------------|-----------------|
| - Bow Cushion  | - Mooring Cover |
| - Bimini Top   | - Transhield    |
| - Cooler Slide | Shipping Cover  |
| - Helm Pad     |                 |

## Color Selection

- Driftwood
- Ice Blue
- Silver Cloud
- Sea Mist Green
- White

Note: These colors may be chosen as a solid hull color or as a side color with a white bottom.

# Features & Performance



## PERFORMANCE BULLETIN



YPB#: PB\_SPT\_IslandBay18\_F90XA\_2015-03-09\_BAY

Test Date 3/09/15



Boat Manufactured By:  
Sportsman Boats • 113 Isaac Way • Summerville, SC 29483  
843-376-2628 • www.sportsmanboatsmfg.com

### PERFORMANCE DATA

RPM	MPH	GPH	MPG
1000	3.3	0.4	8.25
1500	5.3	0.7	7.57
2000	6.7	1.1	6.09
2500	8.9	1.7	5.24
3000	14.0	2.6	5.39
3500	20.5	3.1	6.61
4000	24.7	3.8	6.50
4500	28.5	4.9	5.82
5000	33.0	6.4	5.16
5500	35.6	7.9	4.51
6100	42.4	9.7	4.37

Time to Plane 2.68  
0-30 MPH 5.29

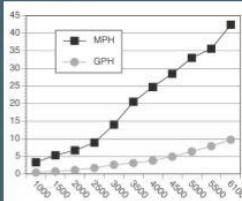

Test performed and verified by Yamaha Applications Engineers.



### Sportsman® Island Bay 18

Length	18' 1"
Beam	7' 1"
Dry Weight (Boat Ltr. Pwd)	1,250 lbs
Maximum HP	90
Fuel Capacity	24 gal
Weight as Tested	2,204 lbs

### F90XA

Horsepower	90 HP
Induction	EFI
Displacement	97 cu in
Weight	372 lbs
Gear Ratio	2.27:1

### ENGINE MOUNTING HEIGHT

Mounting Hole Position	#3
Ventilation Plate Height	Even With Boat Bottom

### PROPELLER/S

Series	Aluminum
Diameter/Pitch	13 x 19
Yamaha Part #	6E5-45941-00-00
Propeller Material	Aluminum

### TEST CONDITIONS

Number of People	2
Air / Water Temperature (Fahrenheit)	75 / 65° F
Elevation (in feet above sea level)	Sea Level
Wind Velocity	10-15 mph

Comments:

Notice to Consumer:

For more information  
Yamaha Motor Corporation, U.S.A.  
OEM Division, Marine Group  
1270 Chaplain Road NW  
Kennesaw, GA 30144 • (800) 88-YAMAHA  
For other Performance Bulletins, visit [www.yamaha-motor.com](http://www.yamaha-motor.com).

© 2015 Yamaha Motor Corporation, U.S.A. All rights reserved.

**Note:** This is posted on our website at  
[http://sportsmanboatsmfg.com/sbmfmg/wp-content/uploads/2015/04/SPT\\_IslandBay18\\_F90XA\\_2015-03-09\\_BAY.pdf](http://sportsmanboatsmfg.com/sbmfmg/wp-content/uploads/2015/04/SPT_IslandBay18_F90XA_2015-03-09_BAY.pdf)

# SPORTSMAN





# Certifications & Registrations

## *NMMA Certification*

Sportsman Boats is certified by the National Marine Manufacturers Association (NMMA). NMMA certification not only meets the standards of the United States Coast Guard (USCG), but goes further to meet the standards set by the ABYC (American Boat and Yacht Counsel). All Sportsman models have been designed, constructed, and thoroughly tested to meet or exceed these standards. For more information about these standards, you may visit <http://www.nmma.org/certification/boats>.

## *Hull Identification Number & Registration*

Sportsman has a permanent record of your boat. This record is documented during the manufacturing process. It is identified by its "Hull Identification Number" (HIN). **The HIN is a 12-digit code located on the starboard side of the transom, just under the Rub Rail.** When contacting your dealer concerning maintenance or warranties, please have your HIN and model number available. This information can be found on your copy of the warranty card. Federal and State laws require a power boat to be registered in the state where it is primarily used. Registration numbers and validation stickers must be displayed according to regulations. The registration certificate must be on board when boating. The boat serial number, or Hull Identification Number (HIN), is required on the registration form. The HIN should be included on all documents or any correspondence.

# Boating Safety

## LIGHTING

Your Sportsman boat is equipped with navigation lights which comply with both Inland and International rules.

## FIRE EXTINGUISHER

At least one Type-1 hand held portable fire extinguisher must be carried on board. For boats over 20' two are required. Check extinguisher regularly for charge status.

## REQUIRED SAFETY EQUIPMENT

The US Coast Guard (USCG) requires that every boat have specific equipment on board. Check with local regulations on mandatory equipment apart from the list of Coast Guard requirements.

## SOUND SIGNALING DEVICES

Your Sportsman boat is equipped with an electric horn which meets the USCG requirements for a sound signal device.

## PERSONAL FLOTATION DEVICE (PFD)



You must have a USCG approved personal flotation device of Type I, II, or III aboard for each passenger, in addition to one Type IV throw able PFD. **Always wear a PFD when boating.** In some states, children are required to wear a PFD at all times. Check your local regulations.



## VISUAL DISTRESS SIGNALS

USCG approved visual distress signals are required for day and night use when operating on US waters. Approved signals include flares, orange smoke, an orange distress flag, or an electric distress light.

# Boating Safety

Being on the water is a great experience, but it can become a bad experience very quickly if safety and maintenance instructions of your boat are not followed. Therefore, warnings and danger notices have been included in order to help you operate and maintain your boat safely. They are defined as follows:

	<b>WARNING</b>	
HAZARDS OR UNSAFE PRACTICES WHICH COULD RESULT IN SEVERE PERSONAL INJURY OR DEATH.		

	<b>DANGER</b>	
IMMEDIATE HAZARDS WHICH WILL RESULT IN SEVERE PERSONAL INJURY OR DEATH.		

Please become familiar with the location and content of the Caution, Warning, and Danger Labels found on your boat.

# Boating Safety



Your Owner's Manual was written to include safety instructions to ensure safe operations. Safety alert symbols are used to show potential personal injury hazards.

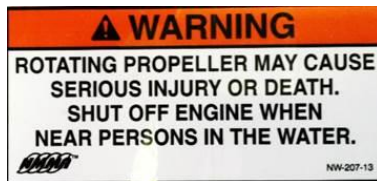

Every precaution has been taken to reduce the risks associated with death, possible injury and damage from fire or explosion. You must also take your own necessary precautions and practice proper maintenance procedures in order to enjoy the optimal safe operation of your boat.

*If your label is damaged. Please call Sportsman's parts department for replacement stickers.*



Your boat produces carbon monoxide and uses flammable fuel. Carbon monoxide can cause brain damage or death. Carbon monoxide is colorless, odorless and extremely dangerous.

**⚠ DANGER**



**Carbon monoxide (CO)** can cause brain damage or death.

Engine and generator exhaust contains odorless and colorless carbon monoxide gas.

Carbon monoxide will be around the back of the boat when engines or generators are running.

Move to fresh air, if you feel nausea, headache, dizziness, or drowsiness.

NW-206-13

**⚠ WARNING**



**Carbon monoxide (CO)** can cause brain damage or death.

Engine and generator exhaust contains odorless and colorless carbon monoxide gas.

Signs of carbon monoxide poisoning include nausea, headache, dizziness, drowsiness and lack of consciousness.

Get fresh air if anyone shows signs of carbon monoxide poisoning.

See Owner's Manual for information regarding carbon monoxide poisoning.

# Boating Safety Label Locations



U.S. COAST GUARD  
**MAXIMUM CAPACITIES**  
**5 PERSONS OR 900 LBS.**  
 1700 LBS, PERSONS, MOTOR, GEAR  
 90 H.P. MOTOR

THIS BOAT COMPLIES WITH U.S. COAST GUARD SAFETY STANDARDS IN EFFECT ON THE DATE OF CERTIFICATION MEETS U.S EPA EVAP STANDARDS USING CERTIFIED COMPONENTS  
 MANUFACTURER: Sportsman Boats Manufacturing, Inc.,  
**MODEL:** 18' Island Bay Summerville, SC

**WARNING**  
 CONTENTS CAN BE UNDER PRESSURE  
 AVOID SERIOUS INJURY OR DEATH FROM  
 FIRE OR EXPLOSION  
 OPEN SLOWLY IN WELL VENTILATED AREA  
 NO SMOKING OR OPEN FLAMES

**DANGER**  
 Carbon monoxide (CO) can cause brain damage or death.  
 Engine and generator exhaust contains odorless and colorless carbon monoxide gas.  
 Carbon monoxide will be around the back of the boat when engines or generators are running.  
 Move to fresh air, if you feel nausea, headache, dizziness, or drowsiness.

**WARNING**  
 Carbon monoxide (CO) can cause brain damage or death.  
 Engine and generator exhaust contains odorless and colorless carbon monoxide gas.  
 Signs of carbon monoxide poisoning include nausea, headache, dizziness, drowsiness and lack of consciousness.  
 Get fresh air if anyone shows signs of carbon monoxide poisoning.  
 See Owner's Manual for information regarding carbon monoxide poisoning.

**WARNING**  
 AVOID SERIOUS INJURY OR DEATH  
 FROM FIRE OR EXPLOSION  
 RESULTING FROM LEAKING FUEL.  
 INSPECT SYSTEM FOR LEAKS AT  
 LEAST ONCE A YEAR.

**WARNING**  
 ROTATING PROPELLER MAY CAUSE  
 SERIOUS INJURY OR DEATH.  
 DO NOT APPROACH OR USE  
 LADDER WHEN ENGINE IS RUNNING.

**WARNING**  
 ROTATING PROPELLER MAY CAUSE  
 SERIOUS INJURY OR DEATH.  
 SHUT OFF ENGINE WHEN  
 NEAR PERSONS IN THE WATER.

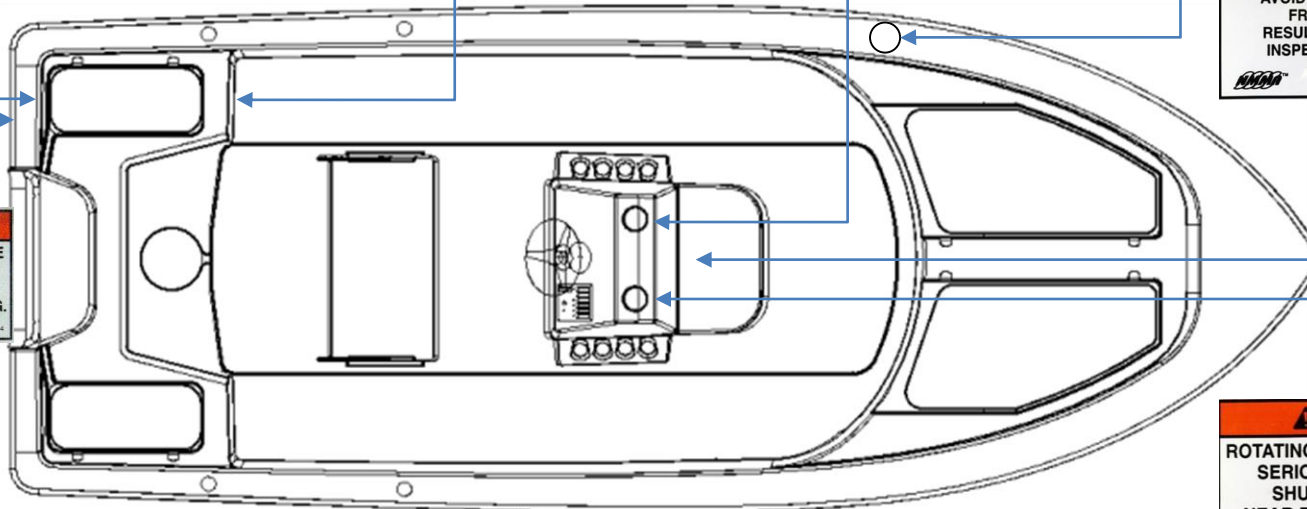

# SPORTSMAN

The Sportsman 18 Island Bay has a 5 Person Capacity. Seating locations are shown below.

For your safety, casting deck is not to be used while boat is in motion.

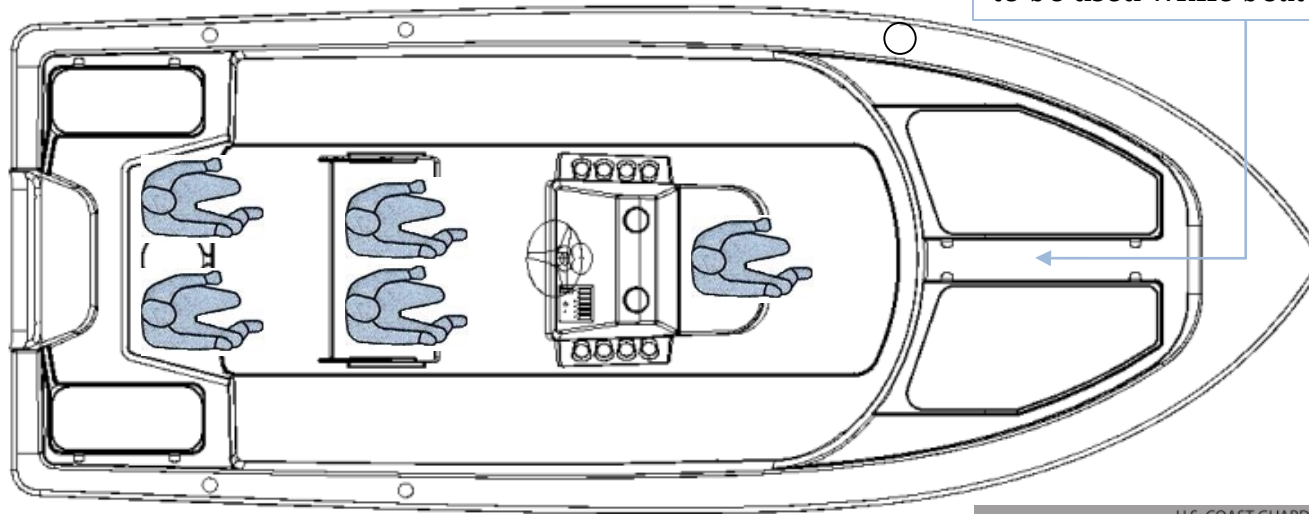

U.S. COAST GUARD  
MAXIMUM CAPACITIES

**5 PERSONS OR 900 LBS.**  
1700 LBS, PERSONS, MOTOR, GEAR  
90 H.P. MOTOR

THIS BOAT COMPLIES WITH U.S. COAST GUARD SAFETY STANDARDS IN EFFECT ON THE DATE OF CERTIFICATION  
MEETS U.S EPA EVAP STANDARDS USING CERTIFIED COMPONENTS  
MANUFACTURER: Sportsman Boats Manufacturing, Inc.,

MODEL: 18' Island Bay

Summerville, SC

# SPORTSMAN

# Electrical & Plumbing Systems

## Simrad Go7



Sportsman offers the Simrad Go7 Multi-function display as a standard feature in the Island series, which integrates the following functions of the boat:

- Structure Scan Capability
- Sonar
- Radar Capability
- Navigation
- Coastal Charts



# SPORTSMAN



# Electrical & Plumbing Systems

## Wire Harness

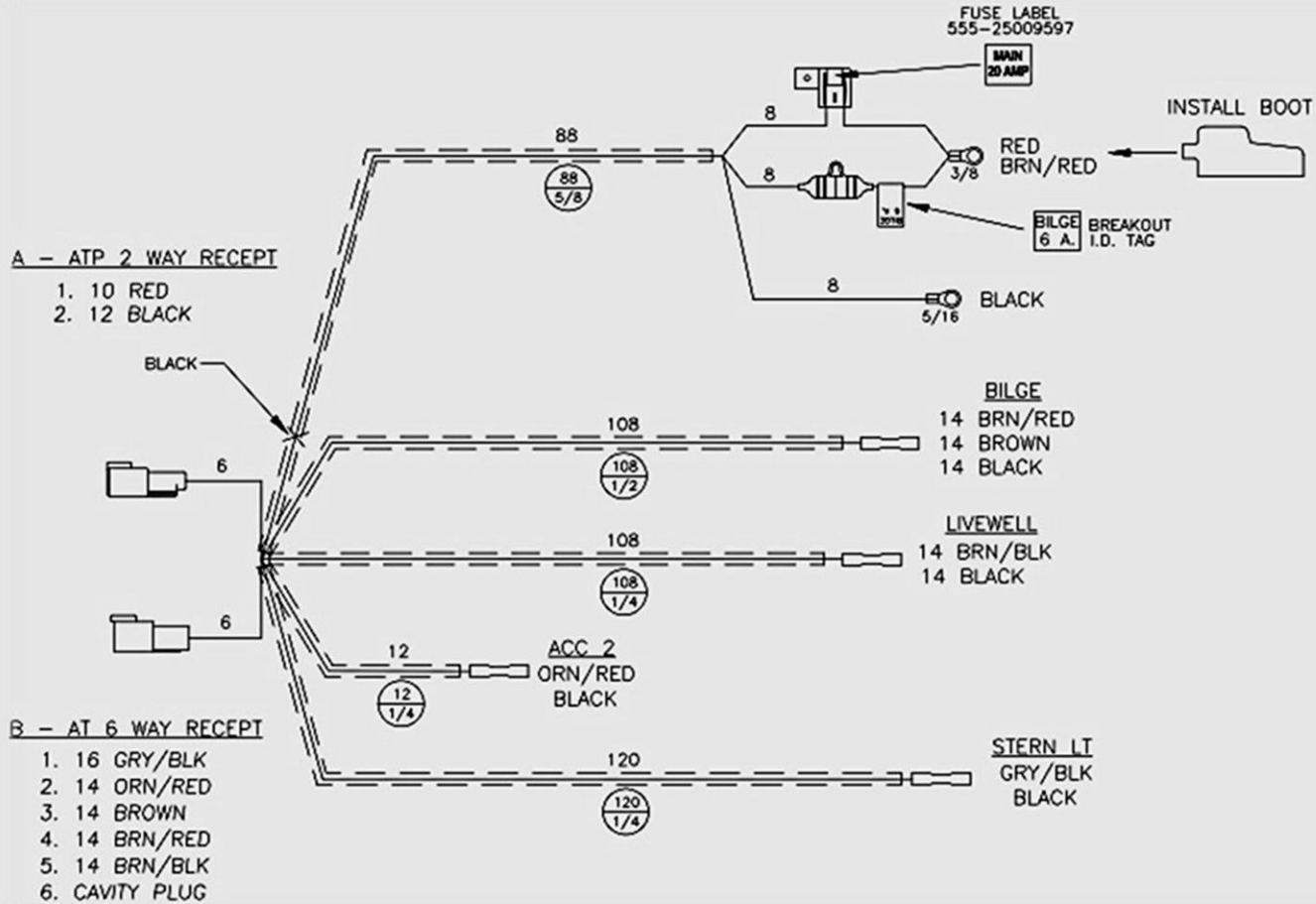

# Electrical & Plumbing Systems

## Lights

The *NAV/ANC Switch* is a 3-position switch on the console that controls the running lights.

- **NAV** position will turn on the red and green navigation lights and the white all-round light for night driving.
- **ANC** turns on the all-round light only for night anchoring. Do not operate the boat in anchor position.
- Off is in the center position.

**Sidelights:** The Island Bay 18 has integrated rub rail navigational lights installed at the bow (see figure to the right). A green light is located on the starboard (right) side and a red light on the port (left) side of the vessel. Each shows an unbroken light over an arc of the horizon of 112.5 degrees and is fixed to show from ahead to just behind the beams of the vessel on its respective side.

**All-round/Anchor Light:** This is a white light placed over the highest unobstructed point of the vessel, showing an unbroken light over an arc of the horizon of 225° and fixed to show from anywhere ahead, to just behind the beams of the vessel. See the figure to the right for location.

Recreational boats are required to display navigation lights between sunset and sunrise and other periods of reduced visibility (fog, rain, haze, etc.) Navigation lights are intended to keep other vessels informed of your presence and course. Your boat is equipped with the navigation lights required by the U.S. Coast Guard at the time of manufacture. It is up to you to make sure they are visible, operational and turned on.

18  Island Bay

Bow Sidelights

All-round/Anchor Light

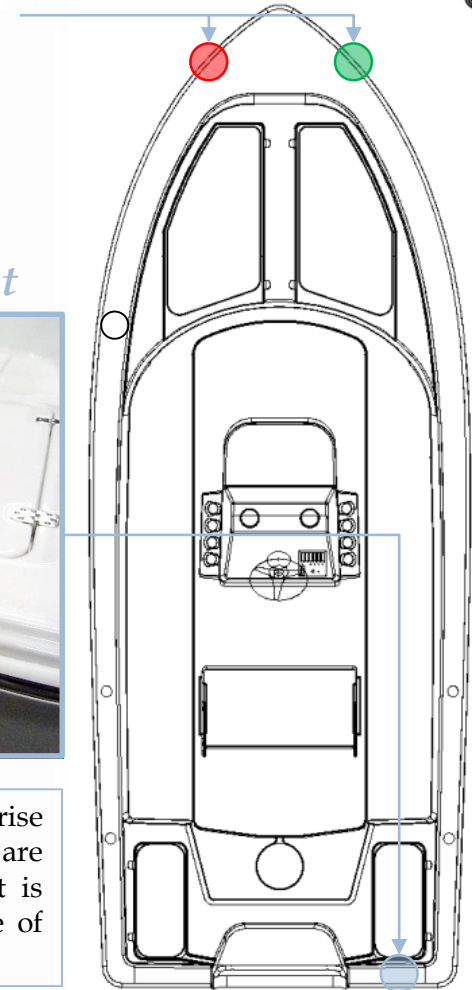

**SPORTSMAN**

# Electrical & Plumbing Systems

## Bilge Pump

A small bilge pump is located on the hull bottom at the stern of your boat. Water is pumped out of a thru-hull fitting located at the port stern of the boat. The pump may be accessed by removing the access lid in the splashwell of your boat, as seen in the figure to the right. You may turn your bilge pump on manually by first turning your master power switch on the dash panel. Then flip on your bilge switch located on the switch panel. Additionally, the bilge pump utilizes a float as an automated switch to turn it on automatically if necessary when the boat is unattended. The bilge pump is designed to remove excess water **only**, and it is **not** intended to stop or prevent rapid accumulation of on-board water due to rough weather, hull damage, or any other unsafe navigational conditions.

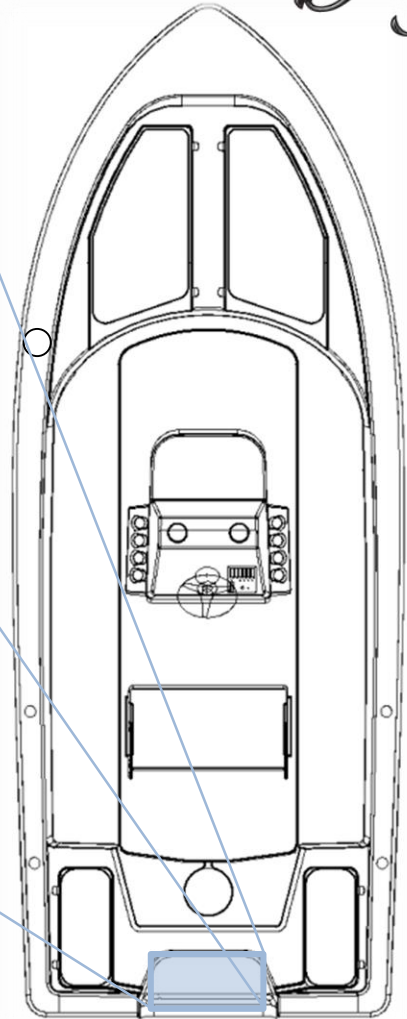

**SPORTSMAN**

# Electrical & Plumbing Systems

## Rear Livewell

Your Island Bay 18 has a rear livewell installed. The pump is located next to the bilge in the [aft] hull of your boat. To operate, turn on the switch labeled "Accessory" at the helm of your boat. In order to begin filling, turn the fill valve at the top of the tank (pictured below) to the "open" position. When the tank is filled, turn the valve to "close" and Insert your rubber drain stop to keep the water in the tank. The livewell has an overflow drain so water cannot exceed a full level and overflow. Pull out the drain plug in the bottom of the tank to drain. Water drains out the thru hull at the transom of your boat.



*Pump To  
Fill Valve*

*Fill Valve*

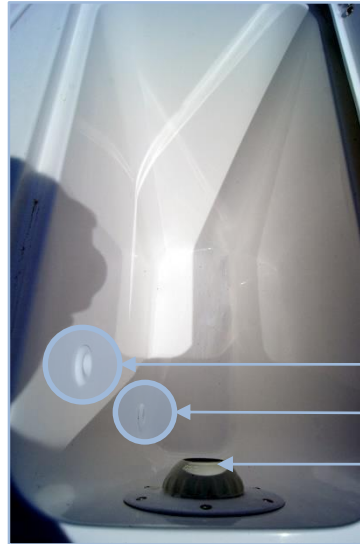

*Overflow  
Drain*

*Drain*

*Fill Valve*

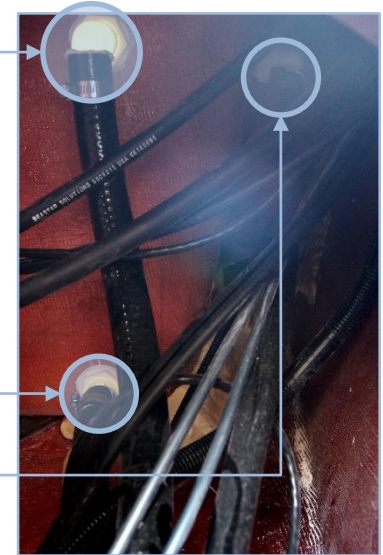

Pictured above is the plumbing system for the rear livewell. The pump is connected with a hose to the fill valve located at the top of the livewell tank. The overflow drain and drain hoses meet in a "Y" joint to drain out the thru hull at the transom.



# Fuel System

The Island Bay 18 comes with a fuel tank installed (28 approximate usable gallon capacity). The gasoline fuel system consists of a fuel tank (located underneath the forward end of the console as shown in the figure), anti-siphon valve, and engine fuel supply line. Your boat contains a new EPA certified fuel system. The system prevents spit-back when filling the tanks and lowers the out gassing emissions through a vent in the new designed fuel fill cap.



Fuel Tank

Fill Cap

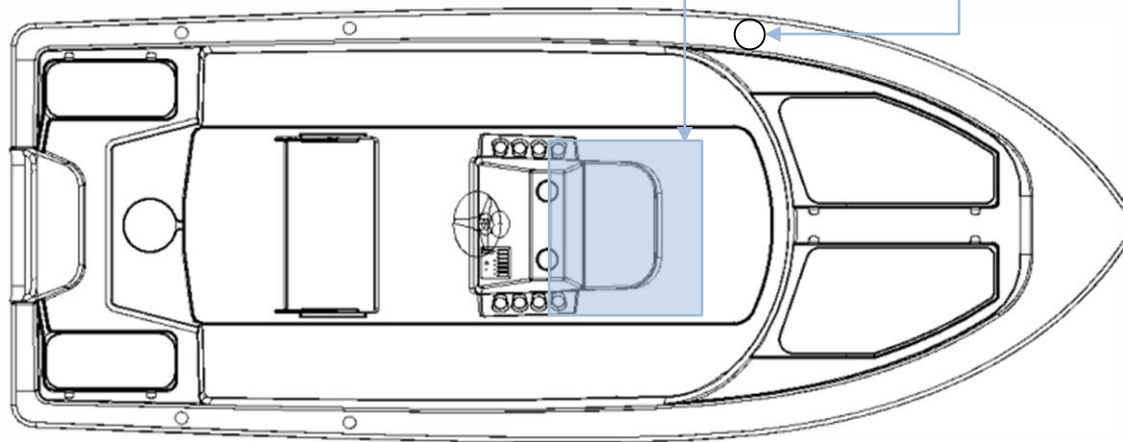

The fuel tank can be accessed through the panel forward of the helm, pictured above. **Pease note that this is an access point. Should you choose to store non-constrained items here while the boat is in transit, they may shift to an inaccessible area under the deck of the boat. We recommend using the provided removable bag to hold items in this space.**

# Fuel System

## Diurnal Fuel System



## EPA DIURNAL FUEL SYSTEMS

**NOTE: Pressure may be present when opening your deck fill, regardless of system type.**



**Only open the fuel cap for refueling**

Note: The first time fuel is introduced to a fuel tank, be aware of the interaction of cold raw fuel vapors replacing air, on occasion a vapor pressure can occur producing spit-back anomalies!

### What is a diurnal fuel system?

Your new vessel is equipped with an Environmental Protection Agency (EPA) compliant diurnal fuel system, designed to reduce fuel emissions to atmosphere using criteria mandated by the EPA. Your vessels fuel tank is required and designed to have a positive pressure (>1PSI) as the sun heats the boat and the fuel in the tank expands or it may be equipped with a carbon canister to catch and contain fuel vapors

Your boats fuel tank also has valves installed inside that are designed to:

1. Produce a clean refueling shut off event
2. Create a 5% vapor space
3. Reduce the propensity of a refueling spit-back event.
4. Allow for appropriate venting when the vessel is stored or trailered. Your fuel cap also contains valves designed to retain fuel vapor (up to 1PSIG) and to allow make up air during engine operation

# Fuel System

## Diurnal Fuel System: Refueling

Your fuel tank capacity will vary from the label or published capacity no less than 5% by law and up to 10% dependent upon the variation from static float due to equipment, occupants and gear etc. (Static Float = attitude in which your boat floats in calm water)

**Fill your vessel fuel tank as normal, stop refueling after two (shut off) clicks of the fuel nozzle.**

Topping off will over ride your fuel system design intent and could cause damage to your vessel due to overflow and will void any and all warranty claims related to fuel spillage.

BluSkies is expressly not responsible for any damage to your vessel subsequent to topping off.

### WARNING

CONTENTS CAN BE UNDER PRESSURE  
AVOID SERIOUS INJURY OR DEATH FROM  
FIRE OR EXPLOSION  
OPEN SLOWLY IN WELL VENTILATED AREA  
NO SMOKING OR OPEN FLAMES

It has been a common practice for many years to top off boats prior to storage or in preparation for a day on the water, however diurnal fuel systems are designed specifically to leave a space in your fuel tank to allow the fuel to expand during the heat of the day. GASOLINE EXPANDS 5%.

### REFUELING

GASOLINE CONTENTS UNDER PRESSURE. FUEL SPRAY MAY OCCUR.

1. OPEN CAP SLOWLY
2. INSERT FUEL NOZZLE
3. BEGIN & CONTINUE FUELING UNTIL FUEL NOZZLE KICKS OFF
4. WAIT 10 SECONDS & CONTINUE FUELING UNTIL NOZZLE KICKS OFF A SECOND TIME
5. RETURN NOZZLE TO PUMP
6. DO NOT TOP OFF



# Fuel System

## Bluskies Diurnal Fuel Systems Operation (cont'd)



### Vapor Space (Ullage) And Refueling Management

Another fuel system necessity to remain EPA compliant it is to keep elevated temperature gasoline from expanding into fuel system areas that are not low permeation rated or otherwise sensitive to raw fuel. A vapor (or ullage) space must be produced at the completion of the filling or refueling operation to ensure systems remain EPA compliant during the diurnal temperature cycle. To effectively manage this system function, BluSkies has created a series of valves that can mount to any marine fuel tank to achieve the appropriate fill level while maintaining ullage space of ~5%. Additionally these valves eliminate the propensity for refueling "spit-back" or tank "well-back", which is another requirement of the EPA regulation.

BluSkies primary ullage valves replace the existing fill and vent locations, while additional grade or tip level valves can be added to any tank to meet American Boat And Yacht Council standards (H-24) which allows vapor venting for boats slanting or sloping when stored, moored, parked or trailered.

The final decision on which system type and ullage valve type and placement that is best for your application should be based on application specific factors such as type and configuration of fuel tank, how much room there on board is for added components, how are the boats likely to be used and stored etc. and of course cost.

Choose individual components to create a compliant system from the following pages or you can turn to our specialists for sound guidance and direction as you go through the process to choosing the appropriate system for your particular vessel application.

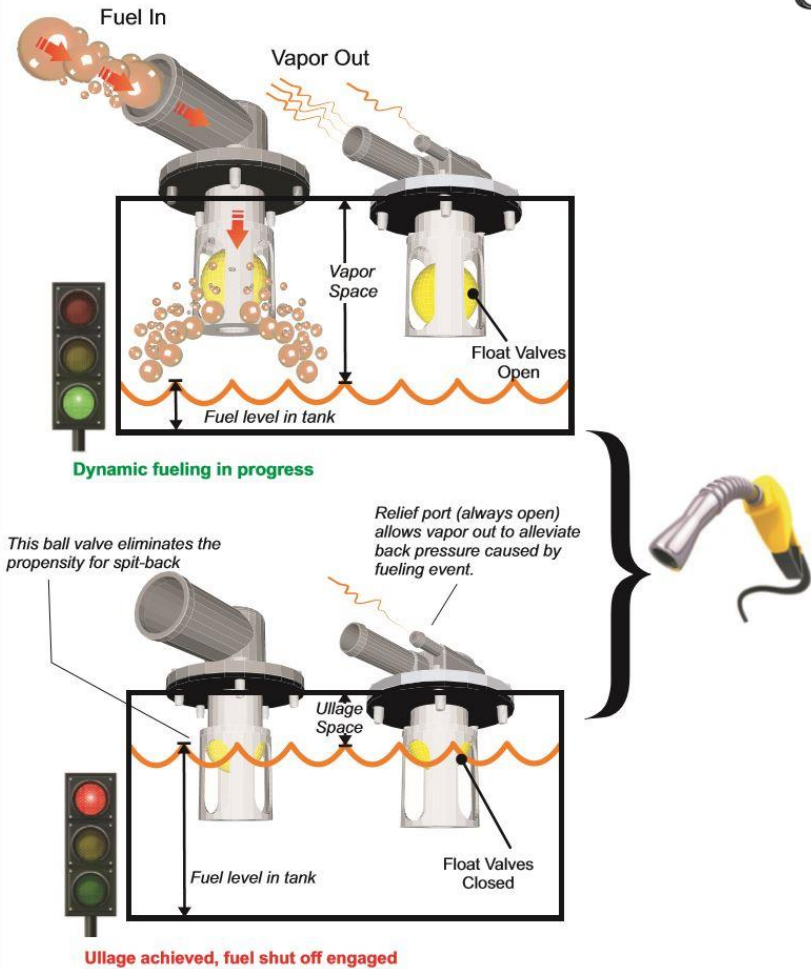



# Fuel System

## Tank Vapor Space & Fluid Management



### Ullage (Vapor Space) Level Attainment Spit-back/Well-back Control

This vent valve shuts off the refueling vapors and creates back pressure to lift the fill valve ball into place.

This fill valve ball is set lower than the vent valve ball but does not close until the refueling vapors are shut off by the vent valve.

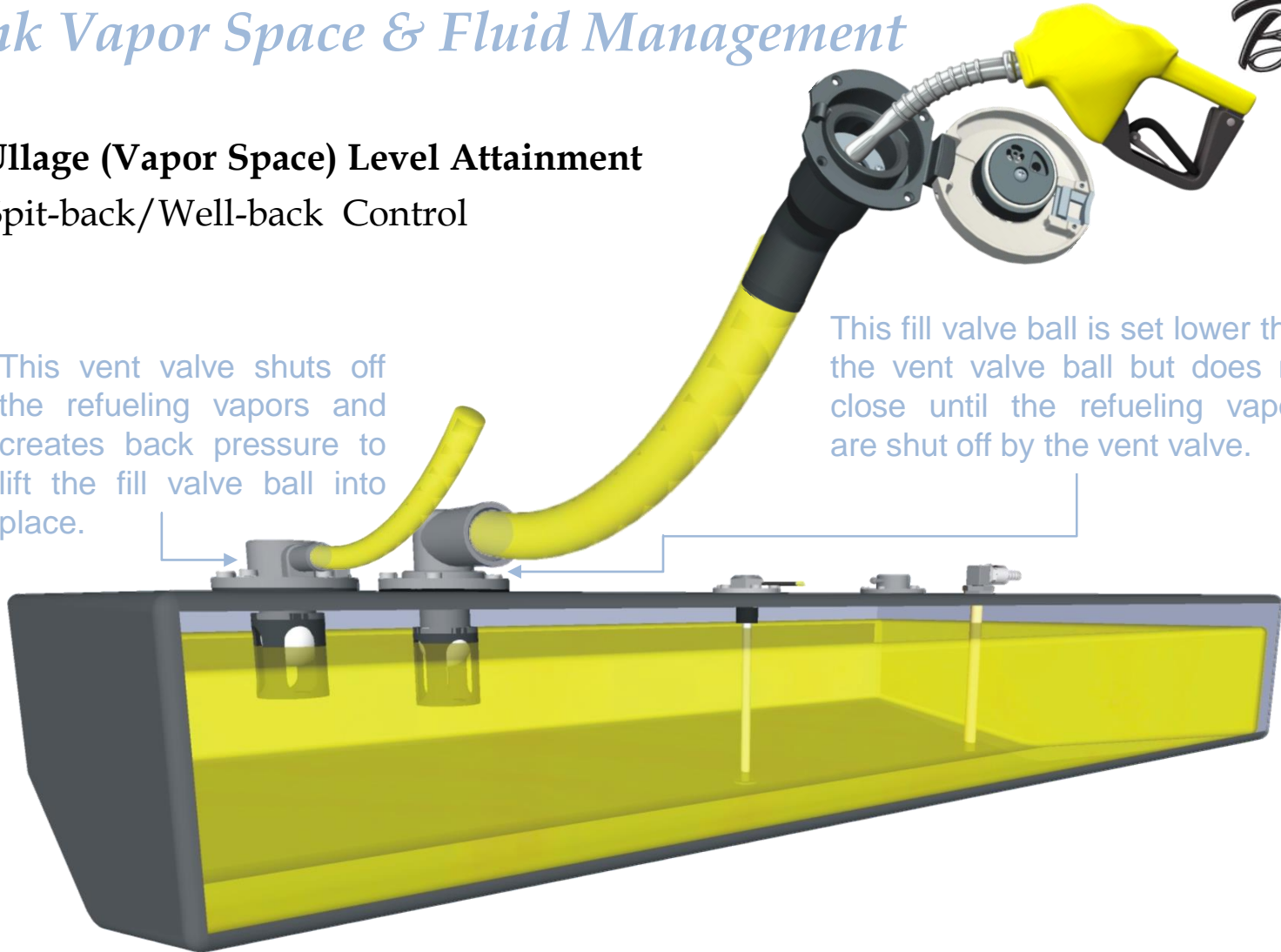

**SPORTSMAN**

# Boating Navigation Rules

There are three main situations that you may encounter with other vessels which could lead to a collision unless the Steering Rules are followed:

- Meeting**: you are approaching another vessel head-on
- Crossing**: you are travelling across the path of another vessel
- Overtaking**: you are passing or being passed by another vessel

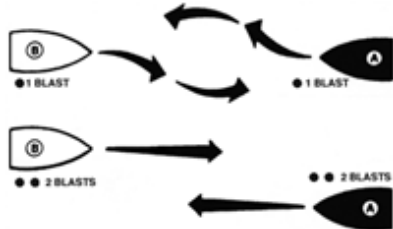

**When Meeting Port-to-port:** Continue on course. The same holds true for meeting starboard-to-starboard.

**When Meeting Head On:** As in a car, both stay to your right and as far apart as practical. Each boat should turn to starboard and pass port-to-port.

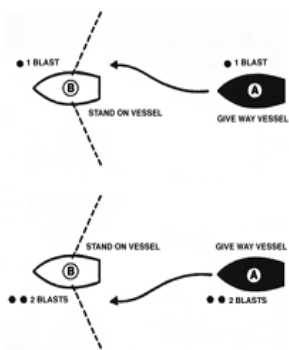

**When Crossing:** Every boat has a "Danger Zone" from straight in front (the bow) to past the middle of its right side. Like when meeting another car at a street intersection, the one on the right has the right of way. You must yield to boats in your Danger Zone. If you are the skipper of the Vessel A in the center of the diagram, you must keep out of the way of any boat that approaches you from any direction within the indicated Danger Zone, as you are the burdened craft. Likewise, boats approaching you from all other directions, except the meeting vessel, must keep clear of you.

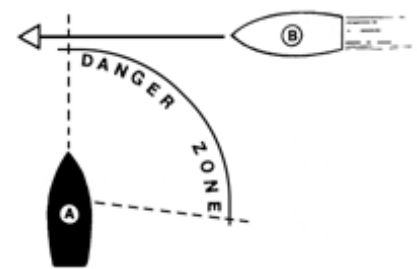

**When Overtaking Another Boat:** The boat being overtaken is the privileged vessel. Only after signaling and receiving an acknowledgment can the overtaking boat pass. (Use one blast to pass on the right, and two blasts to pass on the left.)

**When Being Overtaken:** Be ready for trouble when a power boat passes you in a narrow waterway. As the lead boat, which always has the right of way, stay on your side of the channel and maintain a steady speed so that the overtaking vessel can pass you safely. Use your radio to discuss this with the passing boat.



## *Product Changes*

Sportsman is committed the development of our product line. As a result, equipment described in this manual may have changed or no longer may be available. All information, illustrations and specifications contained in this manual reflect the latest product information available at the time of publication. Sportsman reserves the right to make changes to its boats at any time, without notice. These changes include, but are not limited to: color options, materials, standard and optional equipment, specifications and model availability. If you have any questions about the equipment on your boat, please feel free to contact Sportsman.

## *Insurance*

In most states, the boat owner is legally responsible for damages or injuries they or anyone else operating the boat causes. Some states have laws that require having at least minimum coverage. Before using your boat for the first time, you should contact your dealer, current insurance company, or state boating authority for information regarding insurance requirements in your area. Although it may not be required in your area, responsible boat owners carry liability and property damage for their boat. You should also protect the boat against physical damage and theft.

## *Service*

All warranty work must be performed by an authorized Sportsman Dealer. If a problem is discovered upon taking delivery of, or develops during routine use of the boat that is related to faulty workmanship and/or materials, as stated in the warranty, you need to contact your Sportsman dealer to arrange for your boat to be repaired. **The boat owner is responsible for delivering the boat to the dealer for warranty service.** If you are not near your dealer or any other authorized Sportsman dealer, please contact Sportsman. Likewise, if the dealer fails to repair the problem, please notify Sportsman within 14 days of the work being completed. **Sportsman will not reimburse owners for unauthorized warranty work.**



## Warranty and Services

### **SPORTSMAN BOATS LIMITED WARRANTY**

***Ten-Year Hull Limited Warranty:*** This limited Warranty applies to any Structural Hull Defect (as that term is defined below) if such is due to a failure in material or workmanship and the was reported to Sportsman according to the terms of this Limited Warranty within ten (10) years from the date of the sale to the original purchaser of the Sportsman authorized dealer. Sportsman, in its sole discretion, will either repair or replace the Hull. For purposes of this Limited Warranty, the term “Hull” shall mean the single fiberglass molded shell and integral structural components of a Sportsman Boat, and the term “Structural Hull Defect” shall mean a substantial defect in the Sports Boat’s Hull that causes the boat to be unfit or unsafe for general use as a pleasure craft under normal operating conditions.

***One Year Nonstructural Limited Warranty:*** This Limited Warranty applies to any Nonstructural Defect (as that term is defined below) if such is due to a failure in material or workmanship and the same was reported to Sportsman according to the terms of this Limited Warranty within one (1) year from the date of the sale to the original purchaser of the Sportsman Boat by a Sportsman authorized dealer. Sportsman, in its sole discretion, will either repair or replace the defective component. For purpose of this Limited Warranty, the term “Nonstructural Defect” shall mean a substantial defect in a Sportsman Boat’s components manufactured or installed by Sportsman (other than the Hull) that is not excluded in the exclusions below.

***Registration and Transfer of Limited Warranty:*** Each original purchaser of a Sportsman Boat shall complete and return the boat registration card provided by Sportsman within thirty (30) days of such owner’s purchase of the boat in order to facilitate the processing of warranty claims and for manufacture notification. Except where a Sportsman Boats has been salvaged and resold after a declaration of a total loss or a total loss or a constructive total loss, this Limited Warranty is transferrable to a subsequent owner of the Sportsman Boat. PROVIDED SUCH SUBSEQUENT OWNER FILL OUT AND SEND TO SPORTSMAN A SPORTSMAN WARRANTY TRANSFER FORM (AVAILABLE FROM SPORTSMAN ON REQUEST). A COPY OF THE BILL OF SALE, WHITHIN THIRTY (30) DAYS OF SUCH TRANSFER OR PURCHASE.

**SPORTSMAN**



# Warranty and Services

## SPORTSMAN BOATS LIMITED WARRANTY (cont'd)

### EXCLUSIONS:

This limited Warranty does not apply to any boat that has been salvaged or declared a total loss or constructive total loss for any reason not specifically covered in this Limited Warranty. In addition, this Limited Warranty does not apply to the following "Exclusions:"

- 1) A Hull, component, or other product that has been repaired without authorization of Sportsman or that has been altered in any way that affects its use and operation;
- 2) Expenses related to inspection or warranty service for hauling out, transportation to and from any dealer or Sportsman factory, towing or storage changes, inconvenience or loss of time or income;
- 3) Engines, outdrives, controls, propellers, engine brackets, stereos, depth finder, GPS units, trolling motors, batteries, outriggers bases' and other equipment or accessories that are not manufactured by Sportsman, whether the same is or is not warranted by such other manufacturer;
- 4) Blistering, discoloring, cracking, or crazing of the Gelcoat finish or other surface finishes
- 5) Any Sportsman Boat initially sold at retail by a party other than an authorized Sportsman dealer;
- 6) Damage to, breakage of, or leakage around any windshields, hatches, or apertures;
- 7) Any canvas, zippers, vinyl, upholstery, plastic, or fabric components;
- 8) Discoloration, oxidation, bleeding, or corrosion of any stainless steel or other metal products
- 9) Any Hull, component, or product that has been subject to unreasonable use, tampering, abuse, mishandling, improper maintenance, negligence, improper trailing, alterations, or accidents;
- 10) Any boat, or component or part thereof, that has been used for Commercial Purpose, racing purposes, or has otherwise been operated contrary to any printed instruction provided by Sportsman or contrary to any applicable law (for purposes of this Limited Warranty, the term "**Commercial Purposes**" shall mean the usage of any boat more than fifty percent (50%) for revenue-producing or other business purposes);
- 11) A boat, or component or part thereof, that has been overpowered according to the maximum recommended engine horsepower specified on the capacity plate attached to the boat;
- 12) Machinery, equipment and accessories not installed by Sportsman;
- 13) Condensation of gauges;
- 14) The failure of any part, area, or component of the boat to be dry, whether or not the same was represented as "dry";
- 15) Any representation relating to the speed or weight of any part or component of the boat;
- 16) Normal wear and tear maintenance items, including, but not limited to, filters bulbs, batteries, bungees, anchor rope, trailer finishes, tires, brakes, bearing, and lights;
- 17) Any defect or repair requiring redesign of the boat, except pursuant to the recall provisions of the United States Federal Boat Safety Act of 1971 or the recall laws of the recall laws of any other foreign jurisdiction;
- 18) Dealer preparation, cleaning, and final adjustments and alignments in preparing the boat for delivery or commissioning; or
- 19) Any act of God or force majeure.

# SPORTSMAN



Thank you for your purchase of your Sportsman Boat.

Sportsman Boats Manufacturing, Inc.  
113 Isaac Way · Summerville, South Carolina 29483  
Telephone (843) 376-2628 · Fax (843) 376-2636

Email  
*sales@sportsmanboatsmfg.com*

Website  
*www.sportsmanboatsmfg.com*

P.O. Box 2100  
Summerville, SC 29484



***SPORTSMAN***