

SPORTSMAN

TOURNAMENT 214 Owners Manual



WELCOME TO THE SPORTSMAN TEAM!

Here at Sportsman boats, we take great pride in producing the finest, most well designed, saltwater fishing and pleasure boats on the market today. Our designs incorporate the most modern technology while applying good old "Common Sense" technology as well. From our advanced composite construction, ergonomic console designs, patented "Total Access" hatch, and superior ride and handling characteristics, we think you will agree that Sportsman is setting a new standard.

We do not take lightly the confidence you have placed in us with your decision to purchase your Sportsman boat. We will always strive to provide for you and your family the superior customer service you deserve. We hope that you enjoy your time out on the water as much as we enjoy building your Sportsman boat!

Safe Boating and Tight Lines

Tommy Hancock and Dale Martin



TOURNAMENT 214

Length	21'4"
Beam	8'
Max HP	200 HP
People Capacity	7
Fuel Capacity	64 Gallons
Rear Aerated Livewell	2 x 20 Gallons
Forward Fish Box	22 Gallons
Console Cooler	10 Gallons
Draft	10"
Deadrise @ Transom	15 Degrees
Approx Dry Weight	2000 lbs



SPORTSMAN

21'4"

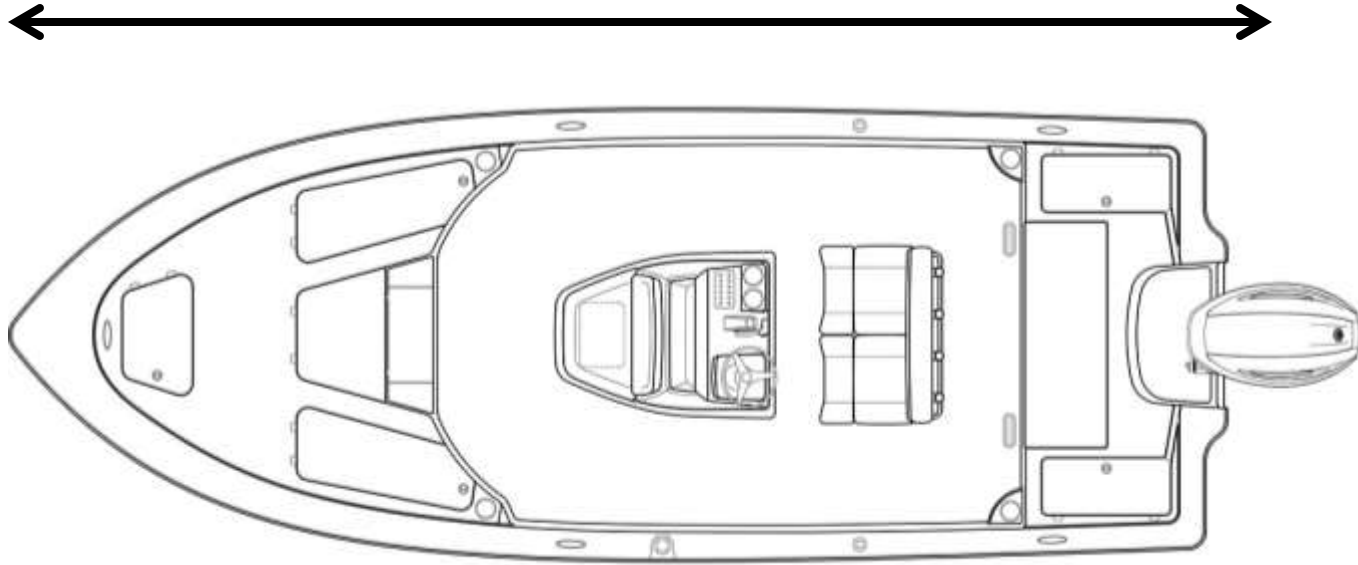

8'





2014 Tournament 214 - Standard Features

- 10 Year Fully Transferable Hull Warranty
- NMMA Certified using ABYC Standards
- Advanced Fiberglass Stringer System (no wood)
- 10 Gallon Livewell Front Seat of Console
- 12 Volt Power Plug
- 2 x 20 Gallon Rear Aerated Livewells
- 2 Flush Mounted Gunwale Rod Holders
- 2 High Speed Livewell Pick Ups
- 6 Vertical Rod Holders on Console (Boats w/o T-Top)
- 64 Gallon Fuel Tank
- All White Hull (sides and bottom)
- Anchor Storage
- Cast Net / Dock Line Storage
- Cockpit Drain Sumps (self bailing cockpit)
- Console w/ Front and Rear Access
- Console Grab Rail
- Console Windscreen
- Deluxe Leaning Post w/ Flip Up Bolsters
- Dual Battery Switch
- Enhanced Transom Angle
- Grip Tex Yacht Style Non-Skid
- Grip Tex Yacht Style Non-Skid
- Horn
- Hydraulic Steering
- Integrated Rub Rail Navigation Lights
- Interior LED Lighting Package
- Large Fish Box
- Large Bow Casting Deck w/ Lockable Storage for Rods
- Large Rear Casting Deck
- Performance Planing Hull w/ Pocket
- Pull Up Cleats
- Rear Boarding Ladder
- Rear Fold Up Bench Seat w/ Lockable Storage
- Rear Total Access Hatch (allows easy access to all systems similar to larger yachts)
- Stainless Cup Holders (6)
- Stainless Steel Drain Covers
- Stainless Steel Rub Rail
- Stainless Steel Wheel w/ Knob
- Step Storage Box
- Trolling Motor Plug / Harness
- Yamaha Digital Gauges

Optional Package

PRO-GUIDE Package Includes:

- *All standard features above
- *Poling Platform & Push Pole Holders
- *Under Gunnel Rod Storage w/ Carpet
- *Trim Tabs

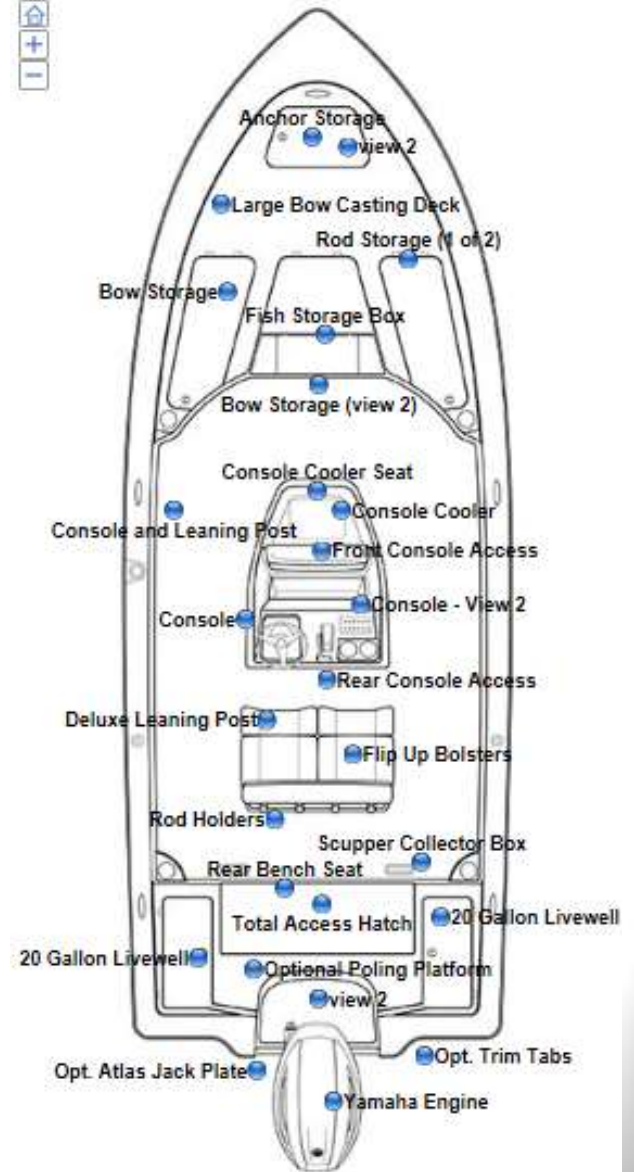

PERFORMANCE BULLETIN



TOURNAMENT 214

Test Date: 12/19/2013

BOAT MODEL	214
LENGTH	21' 4"
BEAM	8' 6"
DRY WEIGHT (Boat Mfr. Pub.)	2000 LBS
MAXIMUM HP	150 HP
FUEL CAPACITY	60 Gallons
WEIGHT AS TESTED	3046 LBS

MANUFACTURER INFO

NAME: Sportsman Boats
 WEB SITE: www.sportsmanboats.com

ENGINE DETAILS

F150XA
 150 HP @ 5500 RPM

PERFORMANCE

RPM	MPH	GPH	MPG
1000	4.8	0.7	6.79
1500	6.6	1.3	5.24
2000	7.9	2.1	3.85
2500	12.0	3.1	3.92
3000	20.2	3.8	5.32
3500	25.3	5.2	4.91
4000	29.7	6.8	4.36
4500	33.8	8.8	3.84
5000	38.3	11.2	3.43
5500	42.1	15.0	2.81
6000	46.6	16.4	2.85

INDUCTION	EFI/DOHC
DISPLACEMENT	2.7 L
WEIGHT	491 LBS
GEAR RATIO	2

ENGINE MOUNTING HEIGHT

MOUNTING HOLE POSITION	3rd Hole
VENTILATION PLATE HEIGHT	Level

PROPELLER'S

BRAND / SERIES	YAMAHA RELIANCE SERIES / SDS HUB
DIAMETER/PITCH	14 1/4 x 18
YAMAHA PART #	68F-45978-10-00 (R)
PROPELLER MATERIAL	POLISHED STAINLESS STEEL

ACCELERATION

TIME TO PLANE	
0 ~ 30 MPH	4.80

TEST CONDITIONS

NUMBER OF PEOPLE	2
AIR / WATER TEMP	60 / 55 °F
ELEVATION (IN FEET ABOVE SEA LEVEL)	Sea Level
WIND VELOCITY	5-10 MPH



NMMA Certified

Sportsman Boats are certified by the National Marine Manufacturers Association (NMMA). NMMA certification not only meets the standards of the United States Coast Guard (USCG), but goes further and meets the standards set by the ABYC (American Boat and Yacht Counsel). All Sportsman models have been designed, constructed and thoroughly tested to meet or exceed these standards. For more information on the 2014 model year standards, you may visit <http://www.nmma.org/certification/programs/boats/> for more details.

Hull Number / Registration

Sportsman has a permanent record of your boat, which was documented during the manufacturing process. It is identified by its "Hull Identification Number" (HIN). The HIN is located on the starboard side of the transom, just under the Rub Rail. When contacting your dealer concerning maintenance or warranties, please have your HIN and model number available. This information can be found on your copy of the warranty card. Federal and State laws require a power boat to be registered in the state where it is primarily used. Registration numbers and validation stickers must be displayed according to regulations. The registration certificate must be on board when boating. The boat serial number, or Hull Identification Number (HIN), is required on the registration form. The HIN should be included on all documents or any correspondence.

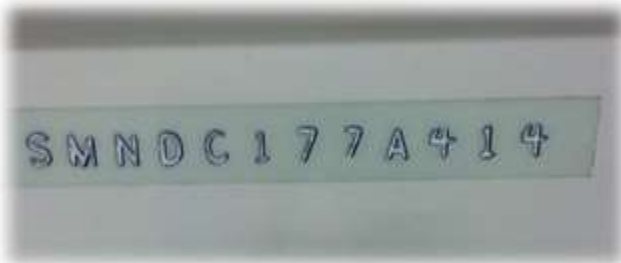

Please fill out the following information. We recommend keeping one copy in your personal records and one copy with your owner's manual. This information will be important to you should you need to contact your Dealer or Sportsman Boats for technical assistance and/or service.

BOAT INFORMATION / SPECIFICATIONS	
MODEL:	HULL SERIAL #:
PURCHASE DATE:	DELIVERED:
IGNITION KEY #:	REGISTRATION #:
DRAFT:	WEIGHT:
VERTICAL CLEARANCE:	
ENGINE / PROPELLER INFORMATION	
ENGINE MAKE:	MODEL:
ENGINE SERIAL #:	
PROPELLER MAKE:	# OF BLADES:
DIAMETER / PITCH:	MODEL:
PART #:	
OPTIONAL EQUIPMENT / OPTION PACKAGES	
TRAILER INFORMATION	
MAKE:	MODEL:
SERIAL #:	GVRM:
ADDITIONAL INFORMATION:	
DEALER	SPORTSMAN
NAME:	PHONE:
PHONE:	REPRESENTATIVE:
SALES PERSON:	ADDRESS:
SERVICE MANGER:	
ADDRESS:	



BOATING SAFETY

REQUIRED SAFETY EQUIPMENT

The US Coast Guard (USCG) requires that every boat have specific equipment on board. Check with local regulations on mandatory equipment apart from the list of Coast Guard requirements.

FIRE EXTINGUISHER

At least one Type-1 hand held portable fire extinguisher must be carried on board. For boats over 20' two are required. Check extinguisher regularly for charge status.

PERSONAL FLOTATION DEVICE (PFD)

You must have a USCG approved personal flotation device of Type I, II, or III aboard for each passenger, in addition to one Type IV throwable PFD. **Always wear a PFD when boating.** In some states, children are required to wear a PFD at all times. Check your local regulations.

SOUND SIGNALING DEVICES

Your Sportsman boat is equipped with an electric horn which meets the USCG requirements for a sound signal device.

VISUAL DISTRESS SIGNALS

USCG approved visual distress signals are required for day and night use when operating on US waters. Approved signals include flares, orange smoke, an orange distress flag, or an electric distress light.

LIGHTING

Your Sportsman boat is equipped with navigation lights which comply with both Inland and International rules.



*Being on the water is a great experience, but it can become a bad experience very quickly if safety and maintaining your boat are not followed. Therefore, your Sportsman manual has been written to include a number of safety instructions and notices in order to help you operate your boat safely and maintain it. These instructions are in the form of **WARNING**, and **DANGER** statements. They are defined as follows:*



WARNING



HAZARDS OR UNSAFE PRACTICES WHICH COULD RESULT IN SEVERE PERSONAL INJURY OR DEATH.



DANGER



IMMEDIATE HAZARDS WHICH WILL RESULT IN SEVERE PERSONAL INJURY OR DEATH.

Please become familiar with the location and content of the Caution, Warning and Danger Labels found on your boat.



Your Owner's Manual was written to include safety instructions to ensure safe operations. Safety alerts symbols are used to show potential personal injury hazards.

Your boat produces carbon monoxide and uses flammable fuel. Carbon monoxide can cause brain damage or death. Carbon monoxide is colorless, odorless and extremely dangerous.

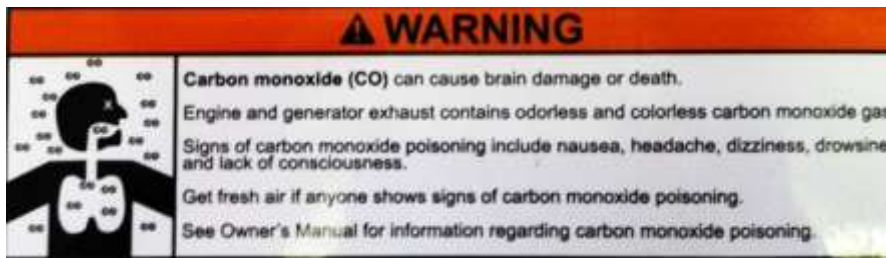
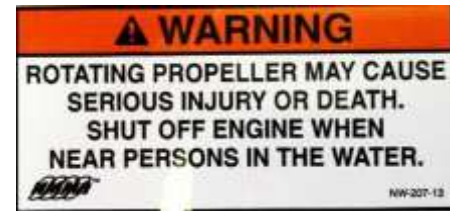
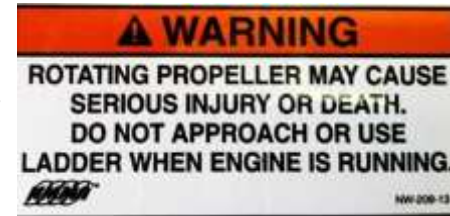

Every precaution has been taken to reduce the risks associated with death, possible injury, damage from fire and explosion. Your own precaution and good maintenance procedures are necessary in order to enjoy safe operation of your boat.

**MEETS U.S. EPA EVAP
STANDARDS USING
CERTIFIED COMPONENTS**

Sportsman Boats Mfg. Summerville, SC



Labels locations

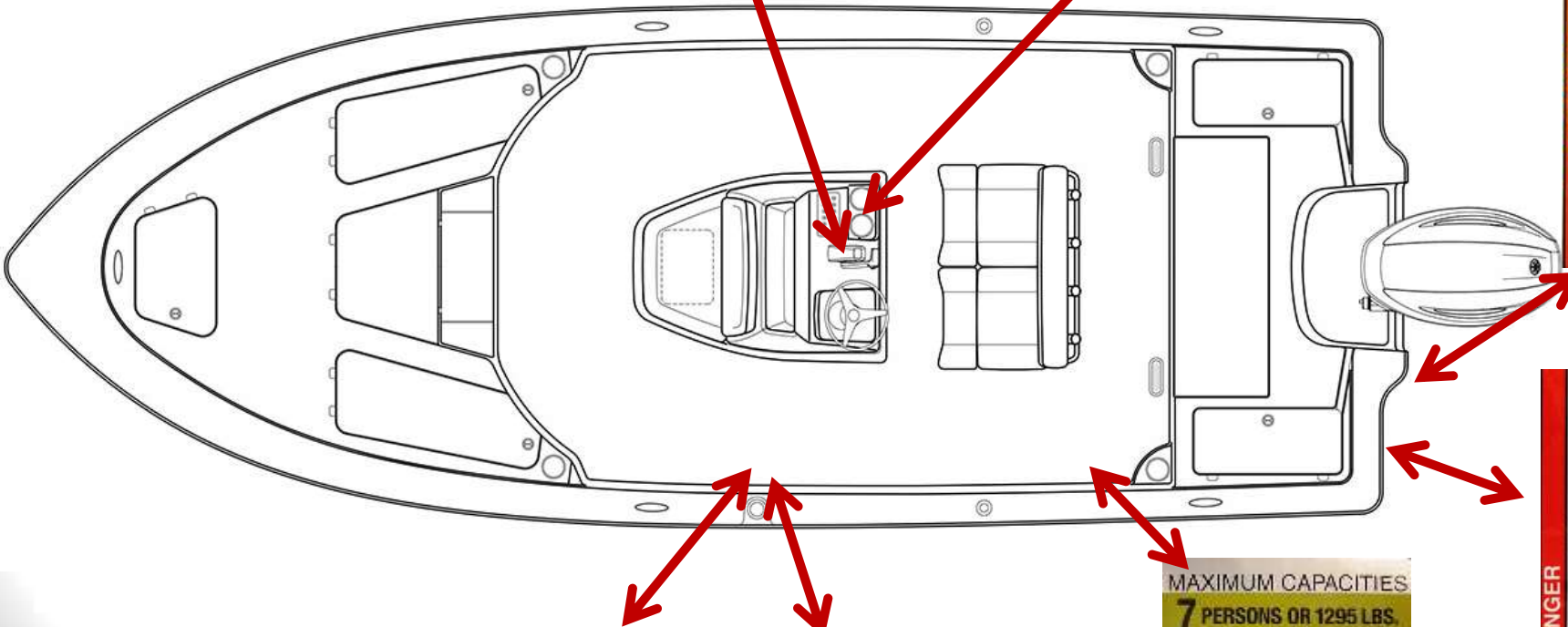

⚠ WARNING
ROTATING PROPELLER MAY CAUSE SERIOUS INJURY OR DEATH. SHUT OFF ENGINE WHEN NEAR PERSONS IN THE WATER.
WARNINGS NW-201-13

⚠ WARNING
Carbon monoxide (CO) can cause brain damage or death.
Engine and generator exhaust contains odorless and colorless carbon monoxide gas. Signs of carbon monoxide poisoning include nausea, headache, dizziness, drowsiness and lack of consciousness.
Get fresh air if anyone shows signs of carbon monoxide poisoning.
See Owner's Manual for information regarding carbon monoxide poisoning.

⚠ WARNING
ROTATING PROPELLER MAY CAUSE SERIOUS INJURY OR DEATH. DO NOT APPROACH OR USE LADDER WHEN ENGINE IS RUNNING.
WARNINGS NW-201-13

⚠ DANGER
Carbon monoxide (CO) can cause brain damage or death.
Engine and generator exhaust contains odorless and colorless carbon monoxide gas.
Carbon monoxide will be around the back of the boat when engines or generators are running. Move to fresh air, if you feel nausea, headache, dizziness, or drowsiness.

WARNINGS NW-201-13

⚠ WARNING
AVOID SERIOUS INJURY OR DEATH FROM FIRE OR EXPLOSION RESULTING FROM LEAKING FUEL. INSPECT SYSTEM FOR LEAKS AT LEAST ONCE A YEAR.
WARNINGS NW-201-13

MEETS U.S. EPA EVAP STANDARDS USING CERTIFIED COMPONENTS
Sportsman Boats Mfg. Summerville, SC

MAXIMUM CAPACITIES
7 PERSONS OR 1295 LBS.
325 LBS. PERSONS, MOTOR, GEAR
200 LBS. MOTOR
THIS BOAT COMPLIES WITH U.S. COAST GUARD SAFETY STANDARDS IN EFFECT ON THE DATE OF CERTIFICATION.
SPORTSMAN BOATS MANUFACTURING, INC.
MANUFACTURED BY Sportsman Boats Manufacturing, Inc.
MODEL: Tournament 214
SUMMERVILLE, SC
SPORTSMAN BOATS MANUFACTURING, INC. 1000 W. STATE ST. SUMMERVILLE, SC 29586
WWW.SPORTSMANBOATS.COM



Master 214 has a 7 Person Capacities, below shows the standing and seated position

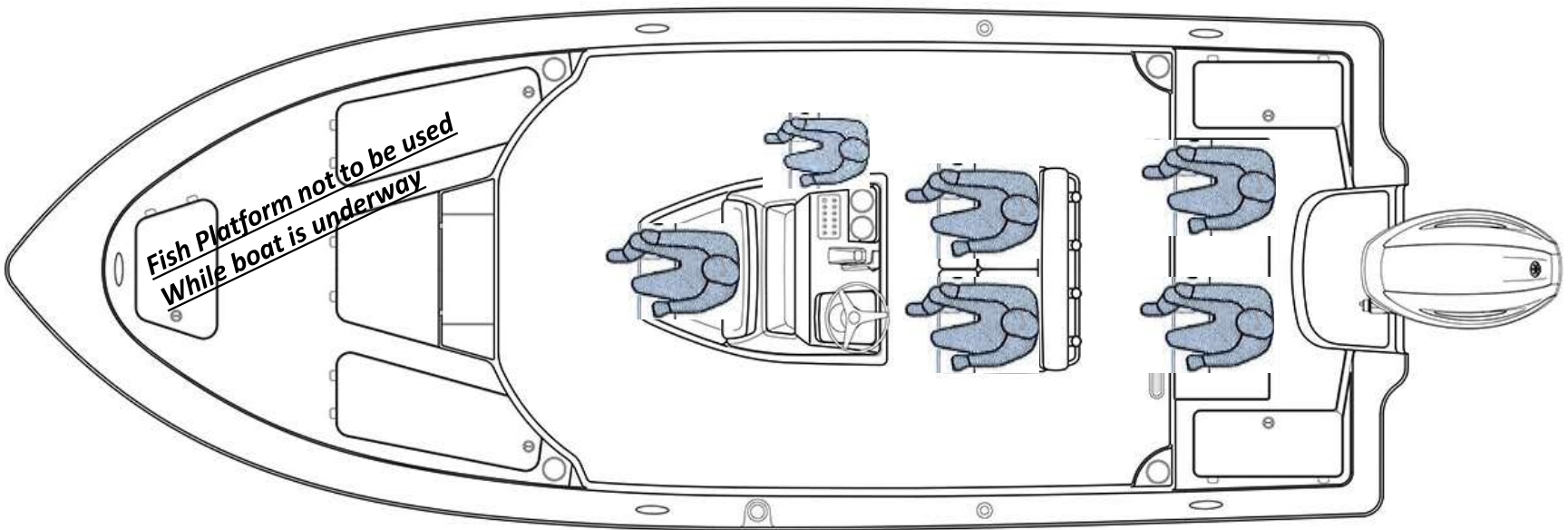

MAXIMUM CAPACITIES

7 PERSONS OR 1295 LBS.

3295 LBS. PERSONS, MOTOR, GEAR
200 H.P. MOTOR

THIS BOAT COMPLIES WITH U.S. COAST GUARD SAFETY STANDARDS IN EFFECT ON THE DATE OF CERTIFICATION

MEETS U.S. EPA OVP STANDARDS USING CERTIFIED COMPONENTS

MANUFACTURER: Sportsman Boats Manufacturing, Inc.

MODEL: Tournament 214

BOAT COMPLIANCE WITH ABOVE REQUIREMENTS IS KEPT BY MANUFACTURER AND DOES NOT EXCEED MANUFACTURER'S LIMITS



NATIONAL PATENT MANUFACTURERS TRADE MARK



Your electrical system:



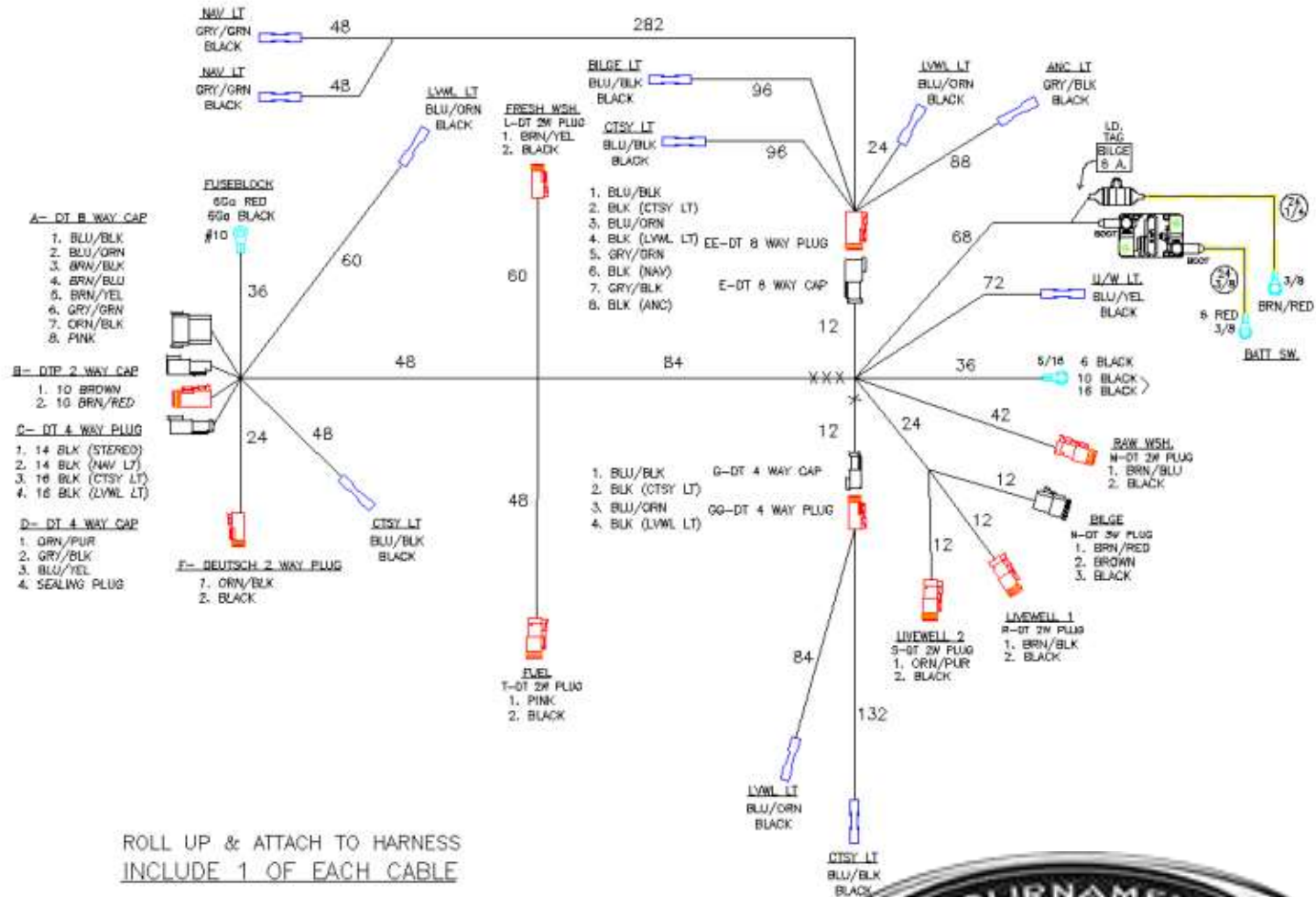

ROLL UP & ATTACH TO HARNESS
INCLUDE 1 OF EACH CABLE

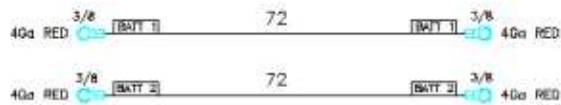

Bilge Pump

Located on the hull bottom at the stern of your boat. Water is pumped out at a through hull fitting located at the starboard aft of the hull. Pump may be accessed by lifting the total access hatch. You may turn your bilge pump on manually with your bilge switch located on the switch panel at the helm of your boat. Once water in the bilge area reaches a certain level the float is engaged and the bilge pump is activated automatically.

Bilge pumps are designed to remove excess water only. They are not intended to prevent rapid accumulation of on-board water due to rough weather, hull damage, or other unsafe navigational conditions.

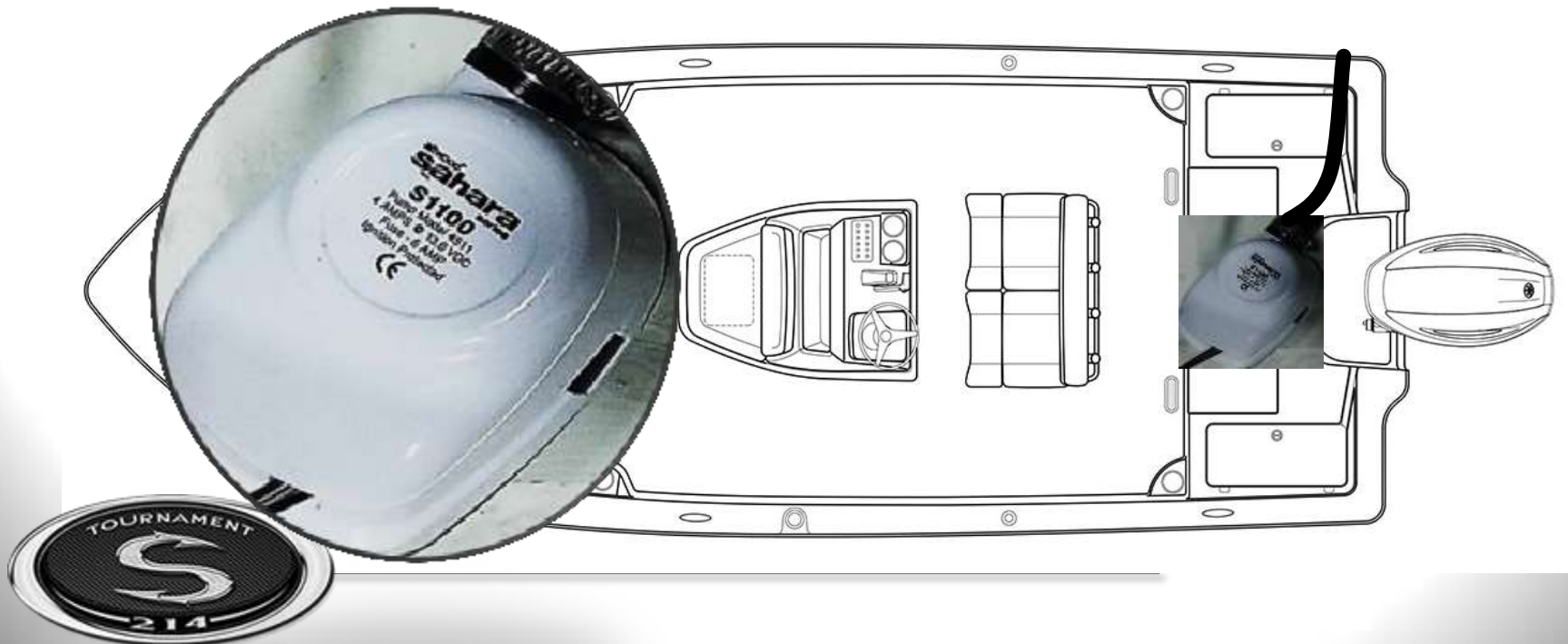

All-round/Anchor light: Is a white light placed over the highest unobstructed point of the vessel, showing an unbroken light over an arc of the horizon of 225 degrees and fixed to show from anywhere ahead, to just behind the beams of the vessel.

Sidelights: Your Masters 214 has rub rail navigational lights installed in the bow gunnel. A green light on the starboard (right) side, and a red light on the port (left) side of a vessel. Each shows an unbroken light over an arc of the horizon of 112.5 degrees and is fixed to show from ahead to just behind the beams of the vessel on its respective side.

The Nav/Anc switch is a 3 position switch that controls the running lights.

*NAV position will turn on the red and green navigation lights and the white all-round light for night driving.

*ANC turns on the all-round light only for night anchoring, do not operate the boat in the anchor position

*Off is in the center position

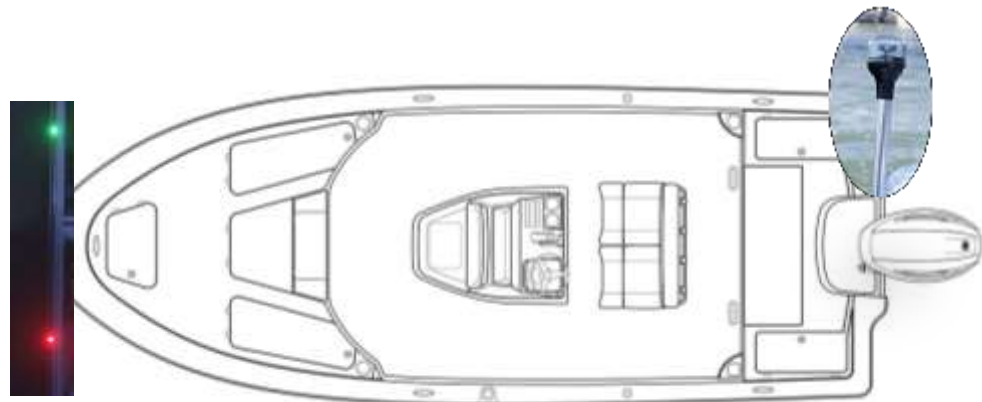

Recreational boats are required to display navigation lights between sunset and sunrise and other periods of reduced visibility (fog, rain, haze, etc.) Navigation lights are intended to keep other vessels informed of your presence and course. Your boat is equipped with the navigation lights required by the U.S. Coast Guard at the time of manufacture. It is up to you to make sure they are visible, operational and turned on.



Your 214 comes with (2) 20 gallon aft livewells and a 10 gallon console livewell. The pumps are located next to the bilge in the hull of your boat. Open the total access hatch for easy access. You may operate your livewells by opening the high speed pickup valve in the bilge area of your boat. Then turn on your switch labeled livewell 1 on your helm switch panel to operate the starboard aft and the livewell under the Front Seat of Console . Then turn on your switch labeled livewell 2 on your helm switch panel to operate the Port aft livewell. With the stand pipe installed in your livewell. Water will not exceed a full level. Also, lights are installed in each livewell for illumination by turning on the switch at the dash.

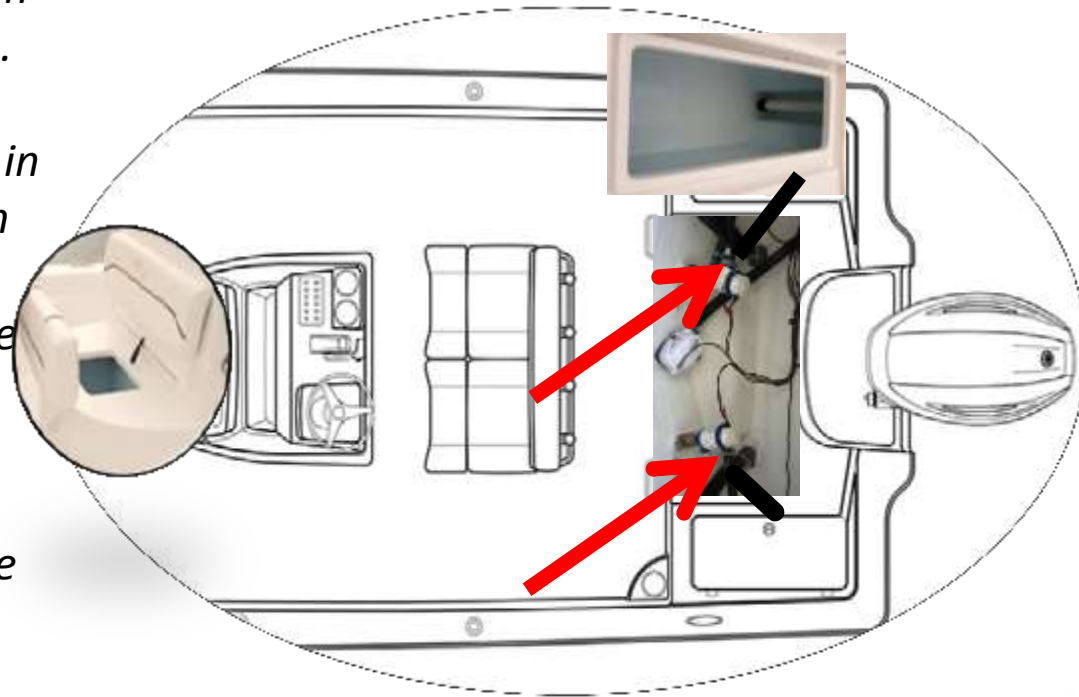

The 214 comes with a 64 gallon fuel tank. The gasoline fuel system consists of a fuel tank, fuel tank vent, anti-siphon valve, engine fuel supply line, fuel fill, and a carbon canister. Your boat contains a new EPA certified fuel system. The system prevents spit back when filling the tanks and lowers the out gassing emissions through the tank and vent

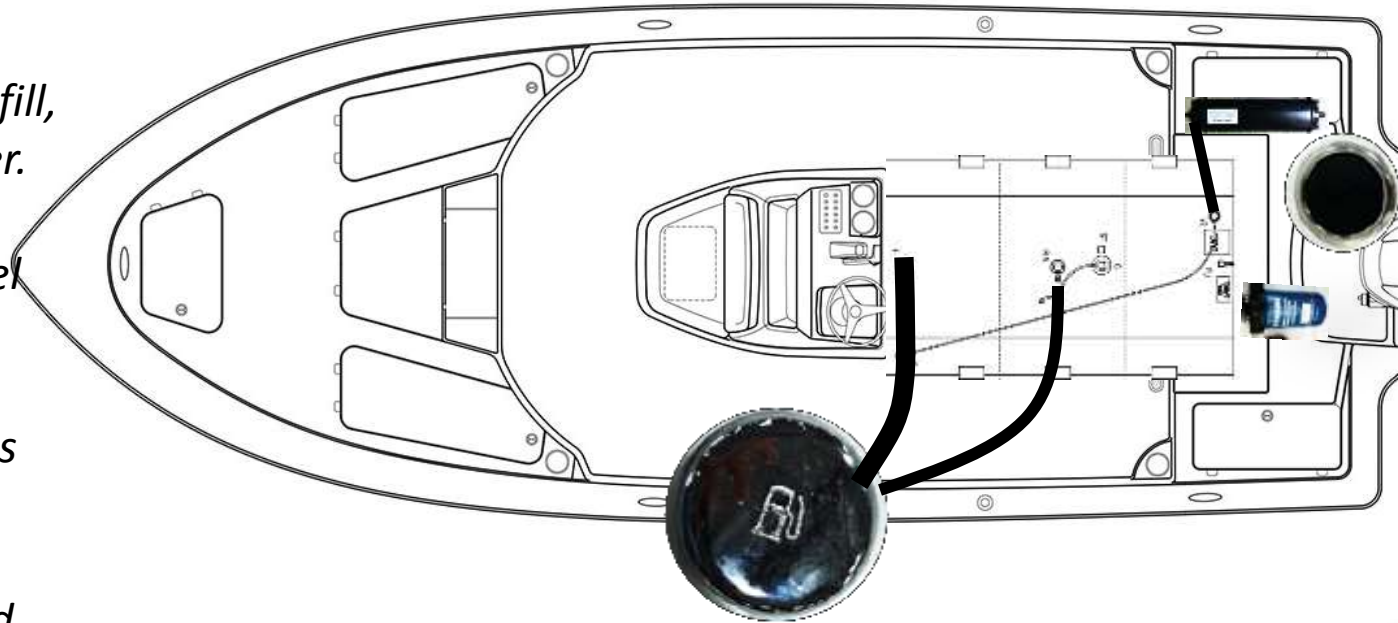

Refueling vapors bypass canister and vent through a vented fill to the fuel pump. This line is then closed with a sealed cap after refueling and diurnal vapors are forced through the canister. This approach provides the least restriction during refueling.

Working together, the NMMA and the ABYC have proposed an industry specification for installing carbon canisters and pressure relief systems, which the EPA and CARB have accepted. The actual detailed ABYC specification is in development. Builders will be asked to demonstrate that their products are built in accordance with these specifications in order to obtain NMMA certification. This will demonstrate to the EPA & CARB that a boat is in compliance. Representatives from boat & engine builders, tank, fill, valve and canister manufacturers, test labs and the U.S. Coast Guard are among the authors of the new specifications.

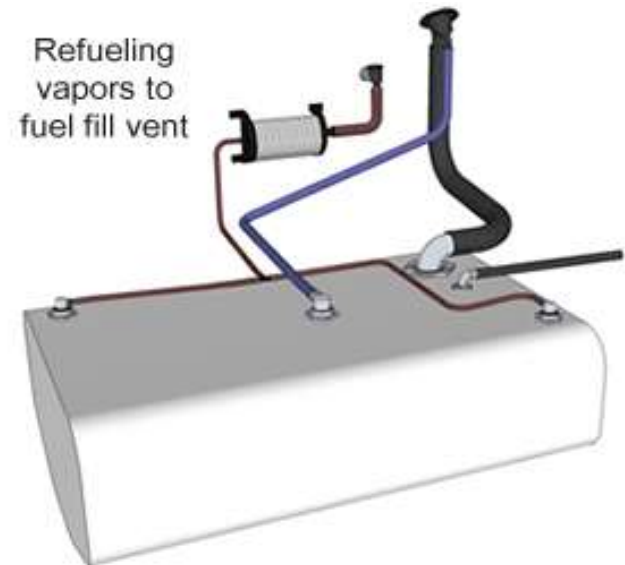

Raw water washdown is an option on your new 214. Rinsing your boat immediately with a powerful water jet washdown makes a fine addition to almost any boat.

The raw water system supplies water by a hose connected to a pump with a shut off valve on your high speed pick up in your bilge compartment. The bottom hose on the pickup is for the raw water system. The pump can easily be accessed when you open your total access hatch. You can operate your washdown by opening the valve handle on the high speed pick up in the bilge area of your boat. Then turn on your switch labeled washdown on the helm of your boat. The washdown outlet can be found on the Starboard side of the Motor Pan.

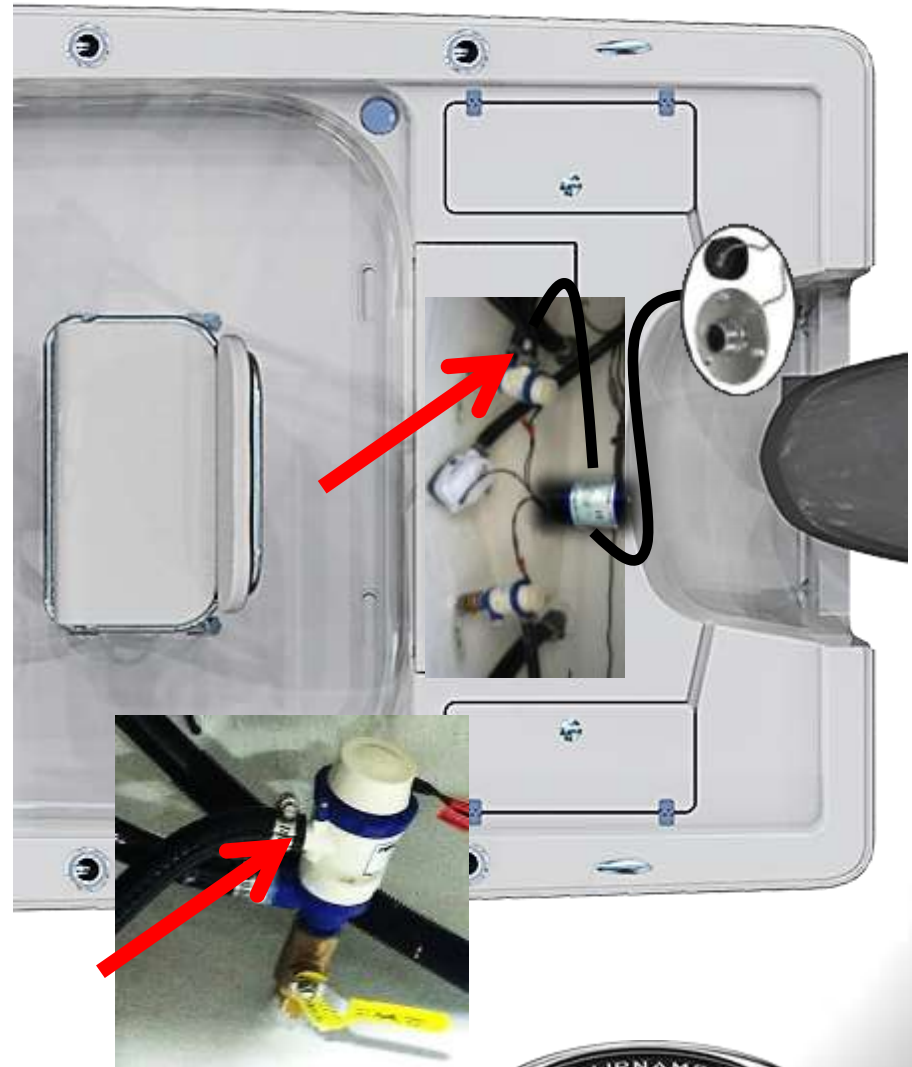

SPORTSMAN

Your 214 may be equipped with the optional Infinity PRV250 marine receiver. This compact receiver is capable of Bluetooth audio streaming and features AM/FM radio. Built to last in the harsh marine environment, the Infinity PRV250 incorporates a waterproof faceplate and a 50W by 4 amplifier. The PRV250 features USB input for USB drive playback, auxiliary input and one pair of RCA output. While in Bluetooth mode, boaters can control volume and track up to 30-feet away. If the stereo option was purchased the 214 comes with 4 marine grade Infinity speakers. You have 2 speakers installed in the bow of your boat. The other 2 are installed in the aft sides of the cockpit



Fresh water is an option on the 214

- *The freshwater fill deck fitting is located on the starboard side of the console next to you Recessed Shower .*
- *Pressurize the freshwater system by turning On the freshwater pump switch on the helm.*
- *The freshwater pump switch is marked ACCESSORY 2 on the helm switch panel.*
- *Turn Off the freshwater pump switch when your boat is not in use or when the freshwater tank is empty.*
- *The pump with filter is mounted inside your console on the starboard side.*
- *Inspect and clean the freshwater filter often (the filter is located on the freshwater pump).*
- *If your boat is to be left unattended for a long period of time, pump the freshwater tank dry to prevent stored water from becoming stagnant and distasteful.*



Underwater light option on the 214. They can be operated with the ACCESSORY 1 switch. These High-Intensity LED Underwater Lights are totally waterproof. A broad flood light effect is created by the engineered optics of the convex light face.



214 Pro-Guide Option Package Includes:

Under Gunnel Rod Racks with mats to protect your reels. Poling Platform with Push Pole Holders.

Caution: Boats w/ jack plate application always be aware of the Motor Cowling hitting the Poling platform. Also to be aware of the Hydraulic steering hitting the jack plate.



Trim Tabs Included with the Pro Guide option Package on your 214.

They are attached to the bottom edge of the transom. When the helm control is pressed, the trim tabs move into position. Water-force on the trim tab surface creates upward pressure, raising the stern and lowering the bow. Trim Tabs improve the performance of your boat in a much wider range of weight, weather and water conditions.

The top portion of the Left switch is marked Port/Bow Down. Pushing this switch deploys the right tab and its movement is indicated by the Left set of the red LED's. All LED's lit is down. The other 3 switches, operate in the same manner, for port and starboard, bow up and bow down. These switches can be pushed individually. Simultaneously or cross controlled, as appropriate.

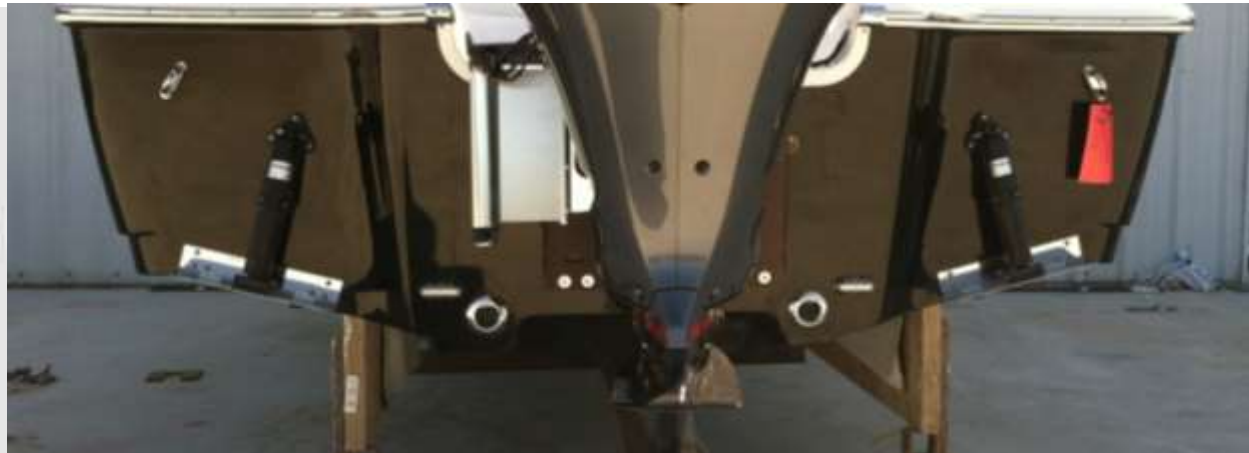

Rules When Encountering Vessels

There are three main situations that you may encounter with other vessels which could lead to a collision unless the Steering Rules are followed:

- **Meeting:** you are approaching another vessel head-on
- **Crossing:** you are travelling across the path of another vessel
- **Overtaking:** you are passing or being passed by another vessel

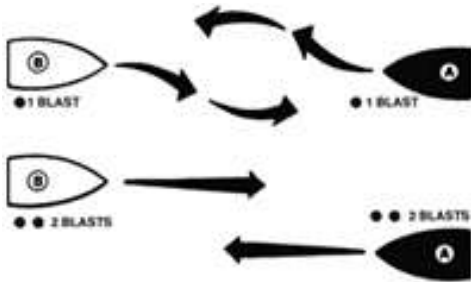
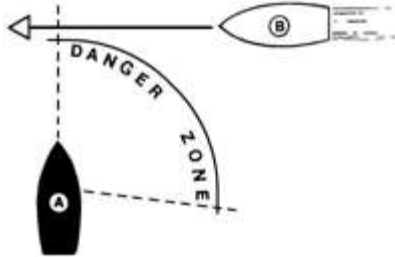

When Crossing: Every boat has a "Danger Zone" from straight in front (the bow) to past the middle of its right side. Like when meeting another car at a street intersection, the one on the right has the right of way. You must yield to boats in your Danger Zone. If you are the skipper of the Vessel A in the center of the diagram, you must keep out of the way of any boat that approaches you from any direction within the indicated Danger Zone, as you are the burdened craft. Likewise, boats approaching you from all other directions, except the meeting vessel, must keep clear of you.

When Meeting Port-to-port: Continue on course. The same holds true for meeting starboard-to-starboard.

When Meeting Head On: As in a car, both stay to your right and as far apart as practical. Each boat should turn to starboard and pass port-to-port.

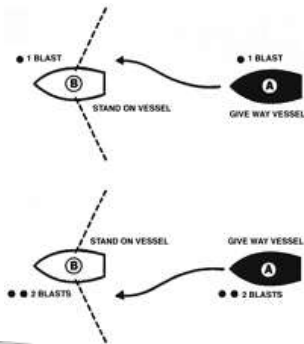

When Overtaking Another Boat: The boat being overtaken is the privileged vessel. Only after signaling and receiving an acknowledgment can the overtaking boat pass. (Use one blast to pass on the right, and two blasts to pass on the left.)

When Being Overtaken: Be ready for trouble when a power boat passes you in a narrow waterway. As the lead boat, which always has the right of way, stay on your side of the channel and maintain a steady speed so that the overtaking vessel can pass you safely. Use your radio to discuss this with the passing boat.



Product Changes

Sportsman is committed to our boats and their development. As a result, equipment described in this manual may have changed or no longer may be available. All information, illustrations and specifications contained in this manual reflect the latest product information available at the time of publication. Sportsman reserves the right to make changes to its boats at any time, without notice. These changes include, but are not limited to: color options, materials, standard and optional equipment, specifications and model availability. If you have any questions about the equipment on your boat, please feel free to contact Sportsman.

Service

All warranty work must be performed by an authorized Sportsman Dealer. If a problem is discovered upon taking delivery of, or develops during routine use of the boat that is related to faulty workmanship and/or materials, as stated in the warranty, you need to contact your Sportsman dealer to arrange for your boat to be repaired. **The boat owner is responsible for delivering the boat to the dealer for warranty service.** If you are not near your dealer or any other authorized Sportsman dealer, please contact Sportsman. Likewise, if the dealer fails to repair the problem, please notify Sportsman within 14 days of the work being completed. **Sportsman will not reimburse owners for unauthorized warranty work.**

Insurance

In most states, the boat owner is legally responsible for damages or injuries they or anyone else operating the boat causes. Some states have laws that require having at least minimum coverage. Before using your boat for the first time, you should contact your dealer, current insurance company, or state boating authority for information regarding insurance requirements in your area. Although it may not be required in your area, responsible boat owners carry liability and property damage for their boat. You should also protect the boat against physical damage and theft.



SPORTSMAN BOATS LIMITED WARRANTY

Ten-Year Hull Limited Warranty: This limited Warranty applies to any Structural Hull Defect (as that term is defined below) if such is due to a failure in material or workmanship and the was reported to Sportsman according to the terms of this Limited Warranty within ten (10) years from the date of the sale to the original purchaser of the Sportsman authorized dealer. Sportsman, in its sole discretion, will either repair or replace the Hull. For purposes of this Limited Warranty, the term “Hull” shall mean the single fiberglass molded shell and integral structural components of a Sportsman Boat, and the term “Structural Hull Defect” shall mean a substantial defect in the Sports Boat’s Hull that causes the boat to be unfit or unsafe for general use as a pleasure craft under normal operating conditions.

One Year Nonstructural Limited Warranty: This Limited Warranty applies to any Nonstructural Defect (as that term is defined below) if such is due to a failure in material or workmanship and the same was reported to Sportsman according to the terms of this Limited Warranty within one (1) year from the date of the sale to the original purchaser of the Sportsman Boat by a Sportsman authorized dealer. Sportsman, in its sole discretion, will either repair or replace the defective component. For purpose of this Limited Warranty, the term “Nonstructural Defect” shall mean a substantial defect in a Sportsman Boat’s components manufactured or installed by Sportsman (other than the Hull) that is not excluded in the exclusions below.

Registration and Transfer of Limited Warranty: Each original purchaser of a Sportsman Boat shall complete and return the boat registration card provided by Sportsman within thirty (30) days of such owner’s purchase of the boat in order to facilitate the processing of warranty claims and for manufacture notification. Except where a Sportsman Boats has been salvaged and resold after a declaration of a total loss or a total loss or a constructive total loss, this Limited Warranty is transferrable to a subsequent owner of the Sportsman Boat. PROVIDED SUCH SUBSEQUENT OWNER FILL OUT AND SEND TO SPORTSMAN A SPORTSMAN WARRANTY TRANSFER FORM (AVAILABLE FROM SPORTSMAN ON REQUEST). A COPY OF THE BILL OF SALE, WITHIN THIRTY (30) DAYS OF SUCH TRANSFER OR PURCHASE.

EXCLUSIONS

This limited Warranty does not apply to any boat that has been salvaged or declared a total loss or constructive total loss for any reason not specifically covered in this Limited Warranty. In addition, this Limited Warranty does not apply to the following “Exclusions”

- 1) A Hull, component, or other product that has been repaired without authorization of Sportsman or that has been altered in any way that affects its use and operation;
- 2) Expenses related to inspection or warranty service for hauling out, transportation to and from any dealer or Sportsman factory, towing or storage changes, inconvenience or loss of time or income;
- 3) Engines, outdrives, controls, propellers, engine brackets, stereos, depth finder, GPS units, trolling motors, batteries, outriggers bases’ and other equipment or accessories that are not manufactured by Sportsman, whether the same is or is not warranted by such other manufacturer;
- 4) Blistering, discoloring, cracking, or crazing of the Gelcoat finish or other surface finishes
- 5) Any Sportsman Boat initially sold at retail by a party other than an authorized Sportsman dealer;
- 6) Damage to, breakage of, or leakage around any windshields, hatches, or apertures;
- 7) Any canvas, zippers, vinyl, upholstery, plastic, or fabric components;
- 8) Discoloration, oxidation, bleeding, or corrosion of any stainless steel or other metal products
- 9) Any Hull, component, or product that has been subject to unreasonable use, tampering, abuse, mishandling, improper maintenance, negligence, improper trailing, alterations, or accidents;
- 10) Any boat, or component or part thereof, that has been used for Commercial Purpose, racing purposes, or has otherwise been operated contrary to any printed instruction provided by Sportsman or contrary to any applicable law (for purposes of this Limited Warranty, the term “Commercial Purposes” shall mean the usage of any boat more than fifty percent (50%) for revenue-producing or other business purposes);
- 11) A boat, or component or part thereof, that has been overpowered according to the maximum recommended engine horsepower specified on the capacity plate attached to the boat;
- 12) Machinery, equipment and accessories not installed by Sportsman;
- 13) Condensation of gauges;
- 14) The failure of any par, area, or component of the boat to be dry, whether or not the same was represented as “dry”;
- 15) Any representation relating to the speed or weight of any part or component of the boat;
- 16) Normal wear and tear maintenance items, including, but not limited to, filters bulbs, batteries, bungees, anchor rope, trailer finishes, tires, brakes, bearing, and lights;
- 17) Any defect or repair requiring redesign of the boat, except pursuant to the recall provisions of the United States Federal Boat Safety Act of 1971 or the recall laws of the recall laws of any other foreign jurisdiction;
- 18) Dealer preparation, cleaning, and final adjustments and alignments in preparing the boat for delivery or commissioning; or
- 19) Any act of God or force majeure.



Thank you for your purchase of your Sportsman Boat.
Please contact us at any of the following:

*Sportsman Boats Manufacturing, Inc.
113 Issac Way
Summerville, SC 29483*

*Office: 843-376-2628
Fax: 843-376-2636*

*P.O. Box 2100
Summerville, SC 29484
Email: sales@sportsmanboatsmfg.com
Visit: www.sportsmanboatsmfg.com*

